

▼ TQ-700E



- Optimized flow technology – three stage pump maximizes productivity of the pump and tool while minimizing heat build-up and down time
- Heat exchanger is standard included
- A quiet (<85 dBA), lightweight pump with a compact footprint – easy to move around and through the work site
- Durable roll cage with an ergonomically sized handle and shielded gauge – a pump that is easy to put into position and safe from on site operational hazards
- Maintenance made simple with a brushless motor designed for continuous usage
- Straightforward operation with a simple pressure set and convenient to use 6 m pendant control – immediate productivity for crews operating the pump
- IP55 Rating for Superior Dust and Water Protection
- Transparent gauge overlays in Nm and Ft.lbs for all Enerpac S and W-Series torque wrenches provide a quick torque reference.

## Lightweight Torque Wrench Pumps



### Four Port Manifold

The TQ-700 offers an optional four wrench manifold as an accessory factory installed. (Add suffix "M" at the end of the model number.

For example: **TQ-700EM**).



### Hydraulic Torque Wrenches

Enerpac offers a complete range of square drive and hexagon cassette torque wrenches.

Page: 183



### Torque Wrench Hoses

Use Enerpac THQ-700 series twin hoses with 700 bar pumps.

| For 700 bar             | Model Nr.       |
|-------------------------|-----------------|
| 6 meters long, 2 hoses  | <b>THQ-706T</b> |
| 12 meters long, 2 hoses | <b>THQ-712T</b> |

The TQ-700E and the W-Series wrenches are a productive combination in wind applications. ▶



# Electric Torque Wrench Pumps



## TQ-700 Applications

The TQ-700 Series pump is ideal for powering hydraulic wrenches for the Power Generation and Wind Markets.

Bolting speed is more complex than how much flow per minute the pump produces. The key is optimising the flow rate across the entire bolting cycle. With more oil flowing at the right time and at the right volume, you achieve the optimized flow for a hydraulic bolting system.

The result of this optimized flow is more bolts tightened faster and a more productive work team.

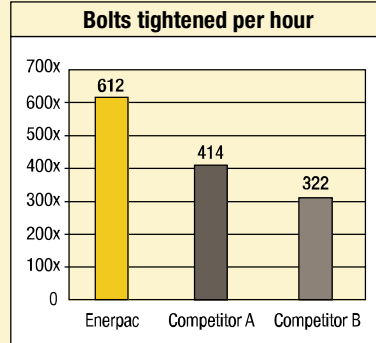

Internal laboratory testing based on standard torquing procedure on a pipe flange with 14, 1 1/2" bolts.

## TQ Series



Reservoir Capacity:  
**4,0 litres**

Flow at Rated Pressure:  
**0,5 l/min**

Motor Size:  
**0,75 kW**

Maximum Operating Pressure:  
**700 bar**



## Torque Wrench Pump Selection Matrix

For optimum speed and performance see the torque wrench, pump and hose selection matrix.

Page: 212

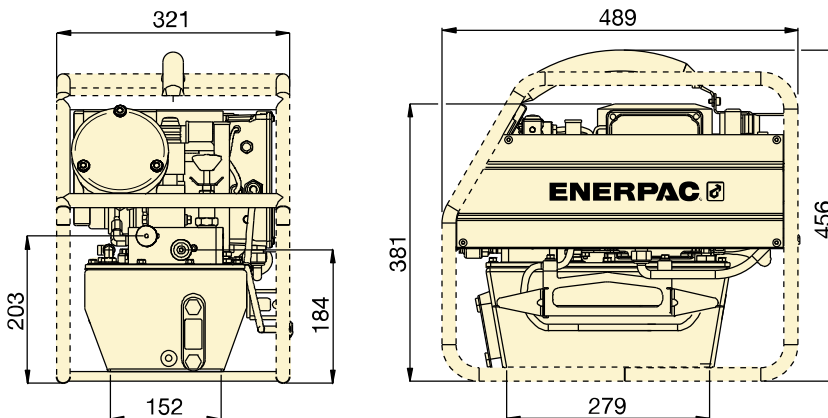

| For Use with Torque Wrenches | Pressure Rating (bar) | Model Number <sup>1)</sup>   | Useable Oil Capacity (litres) | Motor Size (kW) | Motor Electrical Specifications (Volt - Ph - Hz) | Sound Level (dBA) | Weight (kg) |
|------------------------------|-----------------------|------------------------------|-------------------------------|-----------------|--|-------------------|-------------|
| All S and W-Series           | 700                   | <b>TQ-700B</b>               | 4,0                           | 0,75            | 115 - 1 - 50/60                                  | 82 - 85           | 31          |
|                              | 700                   | <b>TQ-700E</b> <sup>2)</sup> | 4,0                           | 0,75            | 230 - 1 - 50                                     | 82 - 85           | 30          |
|                              | 700                   | <b>TQ-700I</b> <sup>3)</sup> | 4,0                           | 0,75            | 230 - 1 - 60                                     | 82 - 85           | 30          |

<sup>1)</sup> All models meet CE safety requirements and all TÜV requirements.

<sup>2)</sup> TQ-700E with European plug and CE EMC directive compliant.

<sup>3)</sup> TQ-700I with NEMA 6-15 plug.

▼ The TQ-700E and the W-Series wrenches are a productive combination.

