

## RAIL TUG | TRACK WELDING AND CUTTING TRACTOR

The Rail Tug is a digitally controlled tractor designed for the mechanization of welding and thermal cutting processes. Featuring a rack and pinion drive system with electronic speed control, Rail Tug creates weld bead geometry which is exact to your specifications, reducing costly over welding and decreasing filler metal usage.

It can be used with semi-flexible tracks for plate and tank work with a minimum radius of 5 m (16 ft) or adapted to bent ring rail for pipe and tube applications.

Hi Flex tracks are suitable for variety of circumferential and irregular surface applications down to minimum radius of 750 mm (30")

Standard ring tracks are available for tube diameters from 200 mm (8") up to 3000 mm (10 ft), whereas custom rolled tracks can be used for tube diameters between 3 m (10 ft) and 10 m (32 ft).

Using a vacuum system allows the tracks to be clamped to non-ferrous surfaces (stainless steel, aluminum etc.)

The Rail Tug economically meets a broad array of welding and cutting applications on flat or curved plate, tube and pipe.

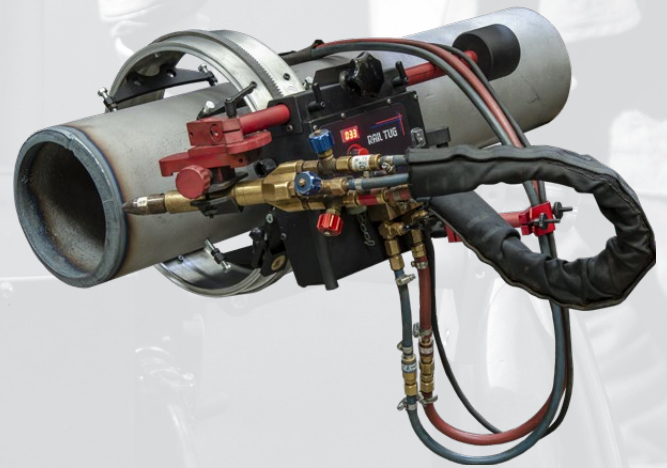

### Applications:

- Trailer manufacturing
- Truck tanks
- Oil tanks
- Water storage tanks
- Pressure vessels
- Bridge girders
- Structural steel
- Structural towers
- Panel welding
- Transformers
- Shipyards
- Any application demanding long continuous welds

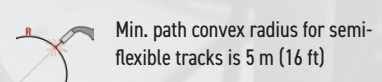
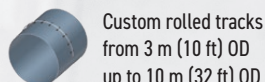
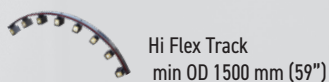
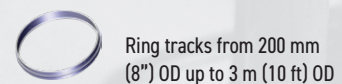
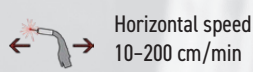

Rail Tug can work in various welding positions on both ferromagnetic and non-ferromagnetic materials by using rack and pinion drive and various tracks equipped with magnetic or vacuum units.

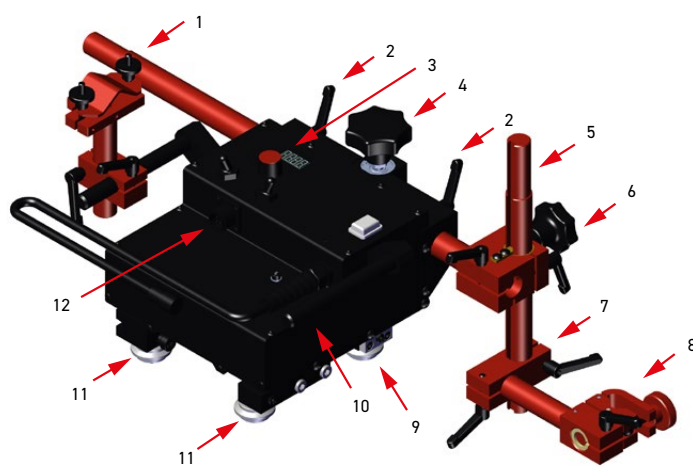
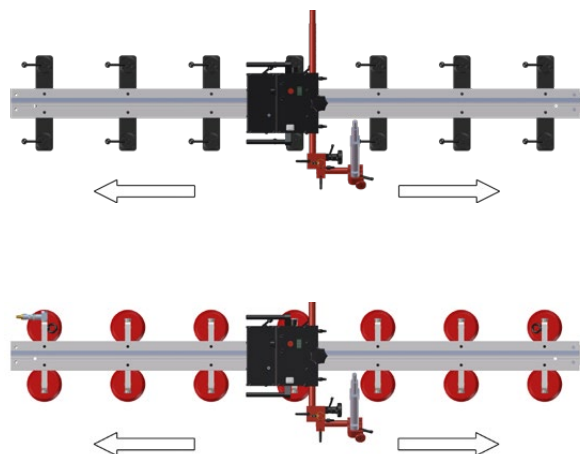
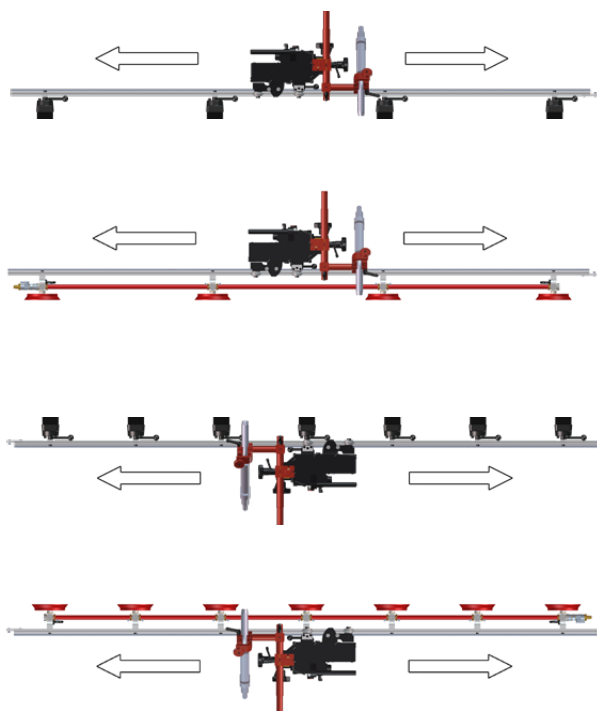
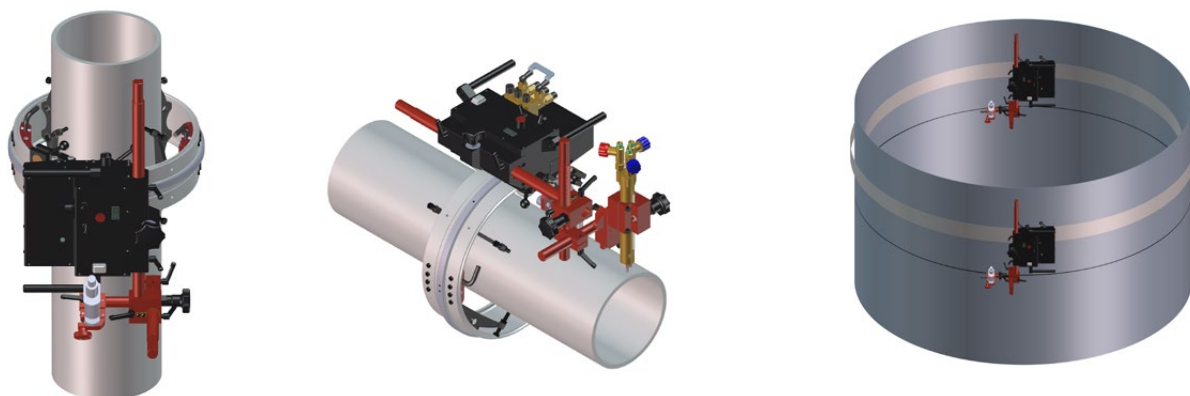

- |  |   |
|--|---|
| 1. 540 mm (21") rack                             | 7. Clamping block with levers                 |
| 2. Rack Locking Levers                           | 8. Short rod torch holder with fits-all clamp |
| 3. Control panel                                 | 9. Guiding Roller                             |
| 4. Rack adjustment knob                          | 10. Carrying handle                           |
| 5. 300 mm (12") rack with 180 mm (7") adjustment | 11. Adjustable Roller                         |
| 6. Rack holder                                   | 12. Arc ignition socket                       |

## Primary features and benefits

- Compact, lightweight design
- Closed-loop speed control system based on electric motor with encoder – ensures increased accuracy of speed
- Rack and pinion drive
- Consistent heat input reduces distortion
- Reduces wasted filler metal – eliminates over welding
- Digital LED display for presetting of travel speed
- Automatic arc on/off initiates welding and travel simultaneously
- Oxy-fuel and plasma cutting possible with optional accessories
- Suitable for variety of circumferential and irregular surface applications down to minimum radius of 100 mm (4")
  - Ring tracks on diameters from 200 mm (8") OD up to 3 m (10 ft) OD
  - Hi-Flex tracks on diameters from 1500 mm (59") OD upwards
  - Custom rolled tracks on diameters from 3 m (10 ft) OD up to 10 m (32 ft) OD
  - Semi-flexible tracks can be bended to minimum radius of 5 m (16 ft) without permanent deformation
- Quick-clamping torch holder mechanism for different types of torches with diameters of 16–22 mm (0.63–0.87"); up to 35 mm (1.38") option
- Precise torch adjustment with screw drive cross slide
- Convenient external 85-250 V power supply
- Improves working environment – removes operator from heat and fumes

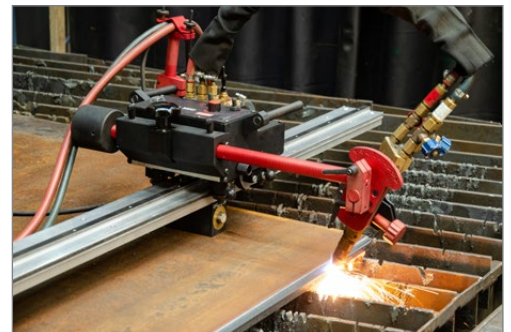
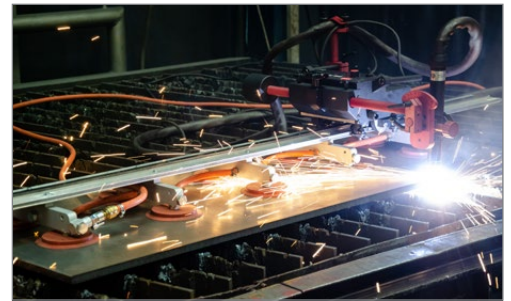

## Standard accessories:



Power cord 3 m (9,7 ft)  
 PWD-0466-18-00-00-0 (230 V CEE)  
 PWD-0466-16-00-00-0 (115 V USA)  
 PWD-0466-23-00-00-0 (230 V UK)



Dual arc ignition cable 6.5 m (21 ft)  
 KBL-0466-17-00-00-0



540 mm (21") Geared Rack  
 RAM-0525-07-00-00-0



Cable anchor  
 UCW-0523-05-01-00-0



Rackholder  
 ZSP-0475-62-00-00-0



300 mm (12") rack  
 with 180 mm (7") adjustment  
 RAM-0523-17-00-00-0



Clamping block with levers  
 KST-0525-11-00-00-0



Short rod torch holder with fits-all clamp  
 UCW-0476-20-00-00-0

## Optional accessories:



PKT-0341-13-00-00-0  
Gear Rack Adjustment Tool



RAM-0475-07-03-00-0  
700 mm (39.4") Geared Rack



PWG-0475-09-00-00-0  
Counterweight  
1.3 kg (2.9 lbs)



RAM-0475-23-00-00-0  
1000 mm (39.4") Geared Rack



PWG-0475-10-00-00-0  
Large Counterweight  
2,6 kg (5,7lbs)



ZCS-0476-06-01-00-0  
16-22 mm Torch Clip



ZRZ-0466-19-00-00-0  
22-35 mm Torch Clamp



ZCS-0475-28-10-00-0  
Standard Torch Holder 28-35 mm  
(1.10-1.38")



203 mm (8") rod  
KLM-0236-00-16-00-0



UCW-0475-28-00-00-0  
Standard Torch Holder with angle adjustment



UCW-0475-08-00-00-0  
Precise Torch Holder with angle and height adjustment



UCW-0475-61-00-00-0  
Machine Barrel Torch Holder  
Ø 30 mm (1.18")



UCW-0475-59-00-00-0  
Precise Machine Torch Holder  
Ø 30 mm (1.18")

UCW-0475-29-00-00-1  
Machine Barrel Torch Holder  
Ø 35 mm (1.38")

UCW-0475-42-00-00-1  
Precise Machine Torch Holder  
Ø 35 mm (1.38")

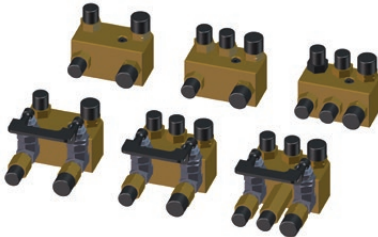

Gas Manifold type	Metric	Imperial
Manifold 2x2	RZD-0475-64-00-00-0	RZD-0475-68-00-00-0
Manifold 2x3	RZD-0475-63-00-00-0	RZD-0475-67-00-00-0
Manifold 3/3	RZD-0475-74-00-00-0	RZD-0475-73-00-00-0
Manifold 2x2 with cut-off valve	RZD-0475-65-00-00-0	RZD-0475-70-00-00-0
Manifold 2/3 with cut-off valve	RZD-0475-66-00-00-0	RZD-0475-69-00-00-0
Manifold 3/3 with cut-off valve	RZD-0475-72-00-00-0	RZD-0475-71-00-00-0

Hi Flex Track min OD 1500 mm  
TRO-0673-00-00-0

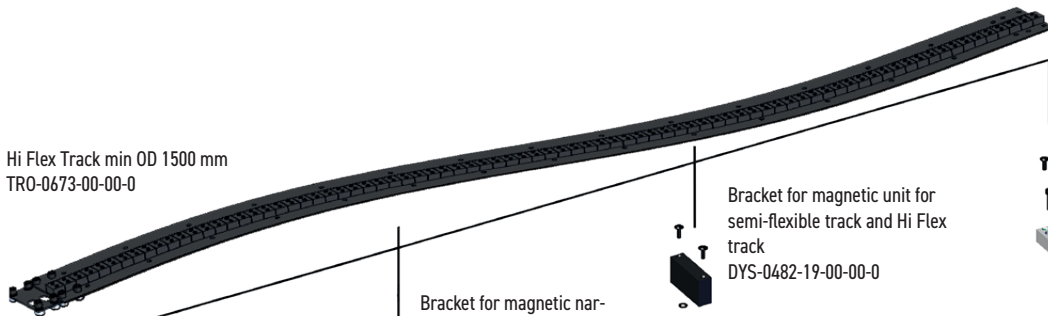

Bracket for magnetic unit for semi-flexible track and Hi Flex track  
DYS-0482-19-00-00-0

Bracket for magnetic narrow unit for semi-flexible track and Hi Flex track  
DYS-0582-10-00-00-0

Bracket for magnetic unit for semi-flexible track and Hi Flex track  
DYS-0482-19-00-00-0

Bracket for vacuum modular unit for semi-flexible track and Hi Flex track  
DYS-0541-11-01-00-0

Vacuum modular unit  
MST-0541-10-02-00-0

Magnetic unit  
ZSP-0475-92-00-00-0

Heat-resistant magnetic unit  
ZSP-0475-93-00-00-0

Magnetic narrow unit with hexagon  
PDS-0582-10-00-02-0

Magnetic pivoting unit  
ZSP-0475-85-00-00-0

Magnetic spacing-adjustable unit  
ZSP-0523-19-00-00-0

The regular rollers should be replaced with the optional Hi Flex track guiding rollers



Set of Hi Flex Track Guiding Rollers (4 pcs)  
Product code: ZSP-0673-07-00-00-0

## Ring tracks

Available on request, diameter can be custom configured within the range from 200 mm OD up to 3000 mm OD (from 8" to 10 ft).

Ring tracks can be equipped with various supports depending on the customer's needs.



Support with bolts  
WSP-0523-14-02-00-0

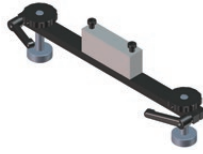

Support with magnets  
WSP-0523-14-12-00-0

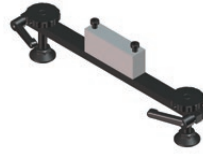

Support with plastic feet  
WSP-0523-14-11-00-0

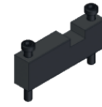

Bracket for ring track supports to expand pipe diameter range by 50 mm downwards  
DYS-0523-14-14-00-0

Rigid track length 2 m (6.5 ft)  
PRW-0482-47-00-00-0

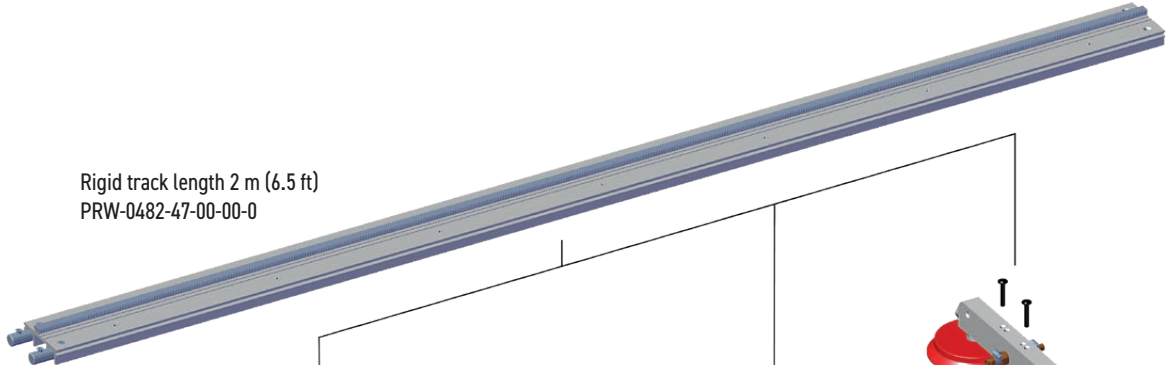

Bracket for magnetic unit for rigid track  
DYS-0482-21-00-00-0

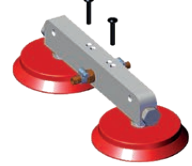

Vacuum modular unit  
MST-0541-10-02-00-0



Magnetic narrow unit with hexagon  
PDS-0582-10-00-02-0



Magnetic unit  
ZSP-0475-92-00-00-0



Lightweight Magnetic Unit  
MST-0677-00-00-00-0



Heat-resistant magnetic unit  
ZSP-0475-93-00-00-0

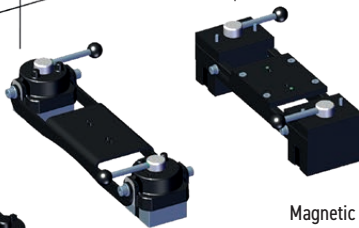

Magnetic pivoting unit  
ZSP-0475-85-00-00-0

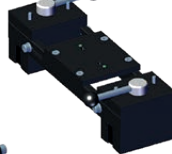

Magnetic spacing-adjustable unit  
ZSP-0523-19-00-00-0

Semi-flexible track length 2 m (6.5 ft) Minimum 5 m (16 ft) curvature radius required  
PRW-0482-15-05-00-0

Semi-flexible tracks can be custom rolled permanently within the radius range from 1.5 m up to 5 m (5 ft up to 16 ft)

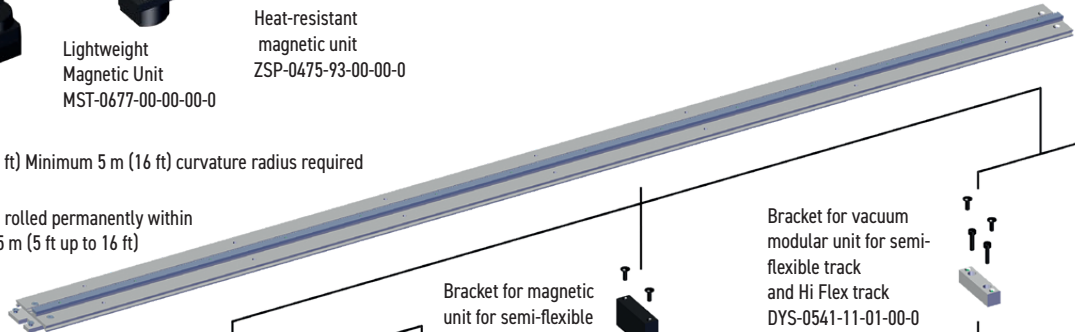

Bracket for magnetic unit for semi-flexible track and Hi Flex track  
DYS-0482-19-00-00-0

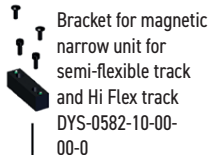

Bracket for magnetic narrow unit for semi-flexible track and Hi Flex track  
DYS-0582-10-00-00-0

Bracket for magnetic unit for semi-flexible track and Hi Flex track  
DYS-0482-19-00-00-0

Bracket for vacuum modular unit for semi-flexible track and Hi Flex track  
DYS-0541-11-01-00-0



Vacuum modular unit  
MST-0541-10-02-00-0

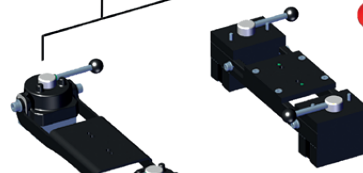

Magnetic spacing-adjustable unit  
ZSP-0523-19-00-00-0

Magnetic pivoting unit  
ZSP-0475-85-00-00-0



Steel track support for semi-flexible track  
WSP-0523-12-01-00-1



Magnetic narrow unit with hexagon  
PDS-0582-10-00-02-0

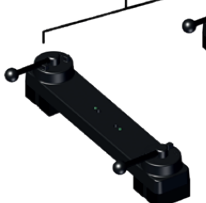

Magnetic unit  
ZSP-0475-92-00-00-0



Heat-resistant magnetic unit  
ZSP-0475-93-00-00-0

Aluminum track support for semi-flexible track  
WSP-0541-11-02-00-0



RAIL TUG Technical specification	
Voltage	1~ 115-230 V, 50-60 Hz
Power	66 W
Welding position (according to EN ISO 6947 and AWS/ASME)	PA / 1F / 1G PB / 2F PC / 2G PD / 4F PE / 4G  PG / 3F (contact your dealer)
Fixing on pipes and round workpieces	Ring tracks Hi Flex tracks Custom rolled tracks Semi-flexible track
Torch type	MIG/MAG, SAW, Plasma, Oxy-fuel
Torch diameter	MIG/MAG SAW, Plasma Oxy-fuel
Horizontal pulling force	300 N
Vertical pulling force	200 N
Horizontal speed	10-200 cm/min (4-80 in/min)
Vertical speed	10-200 cm/min (4-80 in/min)
Weight	10 kg (22 lbs)
Product Code (115-230 V, 50-60 Hz, plug EU)	WOZ-0570-10-20-00-0

#### Standard shipping set:

- Rail Tug tractor
- Cardboard box
- 300 mm (12") rack with 180 mm (7") adjustment
- Rack holder
- Clamping block with levers
- Short rod torch holder with clamp
- Cable anchor
- 6 mm hex wrench
- 6.5 m (21 ft) arc ignition cable
- 3 m (10 ft) power cord
- Operator's Manual



More information available at [www.promotech.eu](http://www.promotech.eu)



All information is subject to change without notice. 21.04



PROMOTECH Sp. z o.o.  
ul. Elewatorska 23/1, 15-620 BIAŁYSTOK, POLAND  
tel. (+48 85) 678 34 05, fax (+48 85) 662 78 77  
marketing@promotech.eu www.promotech.eu

Your local dealer:

