

# **Safety and operating instructions**

## **Hydraulic power packs PAC P9**





# Contents

- Introduction** ..... 5
- About the Safety and operating instructions** ..... 5
- Safety instructions** ..... 5
  - Safety signal words** ..... 5
  - Personal precautions and qualifications** ..... 5
    - Personal protective equipment ..... 5
    - Drugs, alcohol or medication ..... 5
  - Installation, precautions** ..... 6
  - Operation, precautions** ..... 6
  - Maintenance, precautions** ..... 8
  - Storage, precautions** ..... 8
- Overview** ..... 9
  - Design and function** ..... 9
  - Main parts** ..... 9
  - Labels** ..... 9
    - Data plate ..... 9
    - Noise level label ..... 10
    - EHTMA ..... 10
    - EHTMA category ..... 10
    - Safety label ..... 10
    - Fuel label ..... 10
    - Lifting point label ..... 10
- Installation** ..... 10
  - Quick-release couplings** ..... 10
  - Hydraulic oil** ..... 11
  - Hydraulic control and connectors** ..... 11
  - Hoses and connections** ..... 11
    - Connecting hoses ..... 11
    - Disconnecting hoses ..... 12
    - Hose length ..... 12
  - Checking the hydraulic system** ..... 12
- Transport** ..... 12
- Operation** ..... 12
  - Operating** ..... 12
    - Preparation before starting ..... 12
  - Start and stop** ..... 13
    - Starting the engine ..... 13
    - Stopping the engine ..... 14
  - When taking a break** ..... 14
- Maintenance** ..... 14
  - Every day** ..... 14
    - Check hydraulic oil filter ..... 14
  - Every three months** ..... 15
  - Every 300 hours or every year** ..... 15
- Storage** ..... 15
- Disposal** ..... 15
- Troubleshooting** ..... 16

---

<b>Technical data</b> .....	17
<b>Machine data</b> .....	17
<b>Noise declaration statement</b> .....	17
<b>Noise data</b> .....	18
<b>EC Declaration of Conformity</b> .....	19
<b>EC Declaration of Conformity (EC Directive 2006/42/EC)</b> .....	19

## Introduction

Thank you for choosing Chicago Pneumatic brand products. For over a century, the Chicago Pneumatic brand has represented performance and innovation in the pneumatic tool industry. Today the brand is found around the world on a range of pneumatic and hydraulic tools that includes breakers, rock drills, chipping hammers, clay-diggers, picks and busters, scabblers, pumps and a whole lot more.

The Chicago Pneumatic brand is associated with powerful and reliable products that are easy to maintain and that give good value for the money. For more information please visit [www.cp.com](http://www.cp.com)  
Construction Tools EOOD  
7000 Rousse  
Bulgaria

## About the Safety and operating instructions

The aim of the instructions is to provide you with knowledge of how to use the machine in an efficient, safe way. The instructions also give you advice and tell you how to perform regular maintenance on the machine.

Before using the machine for the first time you must read these instructions carefully and understand all of them.

## Safety instructions

To reduce the risk of serious injury or death to yourself or others, read and understand the Safety and operating instruction before installing, operating, repairing, maintaining, or changing accessories on the machine.

Post this Safety and operating instruction at work locations, provide copies to employees, and make sure that everyone reads the Safety and operating instruction before operating or servicing the machine. For professional use only.

In addition, the operator or the operator's employer must assess the specific risks that may be present as a result of each use of the machine.

## Safety signal words

The safety signal words Danger, Warning and Caution have the following meanings:

### DANGER

Indicates a hazardous situation which, if not

avoided, will result in death or serious injury.

### WARNING

Indicates a hazardous situation which, if not avoided, could result in death or serious injury.

### CAUTION

Indicates a hazardous situation which, if not avoided, could result in minor or moderate injury.

## Personal precautions and qualifications

Only qualified and trained persons may operate or maintain the machine. They must be physically able to handle the bulk, weight, and power of the machine. Always use your common sense and good judgement.

### Personal protective equipment

Always use approved protective equipment. Operators and all other persons in the working area must wear protective equipment, including at a minimum:

- Protective helmet
- Hearing protection
- Impact resistant eye protection with side protection
- Respiratory protection when appropriate
- Protective gloves
- Proper protective boots
- Appropriate work overall or similar clothing (not loose-fitting) that covers your arms and legs.

### Drugs, alcohol or medication

#### ▲ **WARNING** Drugs, alcohol or medication

Drugs, alcohol or medication may impair your judgment and powers of concentration. Poor reactions and incorrect assessments can lead to severe accidents or death.

- ▶ Never use the machine when you are tired or under the influence of drugs, alcohol or medication.
- ▶ No person who is under the influence of drugs, alcohol or medication may operate the machine.

## Installation, precautions

### ⚠ **WARNING Hydraulic oil at high pressure**

Thin jets of hydraulic oil under high pressure can penetrate the skin and cause permanent injury.

- ▶ Immediately consult a doctor if hydraulic oil has penetrated the skin.
- ▶ Never use your fingers to check for hydraulic fluid leaks.
- ▶ Keep your face away from any possible leaks.

### ⚠ **WARNING Hydraulic oil**

Spilled hydraulic oil can cause burns, accidents due to slippery conditions and will also harm the environment.

- ▶ Take care of all spilled oil and handle it according to your safety and environmental regulations.
- ▶ Never dismantle the hydraulic machine when the hydraulic oil is hot.

### ⚠ **CAUTION Skin eczema**

Hydraulic oil can cause eczema if it comes in contact with the skin.

- ▶ Avoid getting hydraulic oil on your hands.
- ▶ Always use protective gloves when working with hydraulic oil.
- ▶ Wash hands after contact with hydraulic oil.

### ⚠ **CAUTION Moving parts**

Risk for crushed hands and fingers.

- ▶ Never check bores or passages with hands or fingers.
- ▶ Never operate the machine when adjusting the choke control or fuel valve.

## Operation, precautions

### ⚠ **DANGER Explosion hazard**

When working on certain materials and when using certain materials in machine parts, sparks and ignition can occur. Explosions will lead to severe injuries or death.

- ▶ Never operate the machine in any explosive environment.
- ▶ Never use the machine near flammable materials, fumes or dust.
- ▶ Make sure that there are no undetected sources of gas or explosives.

### ⚠ **DANGER Fuel hazard**

The fuel (petrol and oil) is extremely flammable and petrol fumes can explode when ignited, causing serious injury or death.

- ▶ Protect your skin from contact with the fuel. If fuel has penetrated the skin, consult a qualified health professional.
- ▶ Never remove the filler cap, and never fill the fuel tank when the machine is hot.
- ▶ Release the filler cap slowly to let pressure escape.
- ▶ Never overfill the fuel tank.
- ▶ Make sure the filler cap is screwed on when the machine is used.
- ▶ Avoid spilling fuel on the machine, wipe off any spilled fuel.
- ▶ Check regularly for fuel leaks. Never use the machine if it is leaking fuel.
- ▶ Never use the machine in the proximity of material that can generate sparks. Remove all hot or spark-generating devices before starting the machine.
- ▶ Never smoke when filling the fuel tank or when working with the machine or servicing it.
- ▶ Only store fuel in a container that is specially constructed and approved for the purpose.
- ▶ Consumed petrol and oil containers must be taken care of and returned to the retailer.
- ▶ Never use your fingers to check for fluid leaks.

### ⚠ **DANGER Exhaust gas hazard**

The exhaust gas from the machine's combustion engine contains carbon monoxide which is poisonous, and chemicals known to the State of California and other authorities to cause cancer, birth defects, or other reproductive harm. Inhalation of exhaust fumes can cause serious injury, illness, or death.

- ▶ Never inhale exhaust fumes.
- ▶ Never operate the machine indoors or in a poorly ventilated area.
- ▶ Never stand in a deep hole, ditch, or similar surrounding during operating.

**▲ WARNING Dust and fume hazard**

Dusts and/or fumes generated or dispersed when using the machine may cause serious and permanent respiratory disease, illness, or other bodily injury (for example, silicosis or other irreversible lung disease that can be fatal, cancer, birth defects, and/or skin inflammation).

Some dusts and fumes created by drilling, breaking, hammering, sawing, grinding and other construction activities contain substances known to the State of California and other authorities to cause respiratory disease, cancer, birth defects, or other reproductive harm. Some examples of such substances are:

- Crystalline silica, cement, and other masonry products.
- Arsenic and chromium from chemically-treated rubber.
- Lead from lead-based paints.

Dust and fumes in the air can be invisible to the naked eye, so do not rely on eye sight to determine if there is dust or fumes in the air.

To reduce the risk of exposure to dust and fumes, do all of the following:

- ▶ Perform site-specific risk assessment. The risk assessment should include dust and fumes created by the use of the machine and the potential for disturbing existing dust.
- ▶ Use proper engineering controls to minimize the amount of dust and fumes in the air and to minimize build-up on equipment, surfaces, clothing, and body parts. Examples of controls include: exhaust ventilation and dust collection systems, water sprays, and wet drilling. Control dusts and fumes at the source where possible. Make sure that controls are properly installed, maintained and correctly used.
- ▶ Wear, maintain and correctly use respiratory protection as instructed by your employer and as required by occupational health and safety regulations. The respiratory protection must be effective for the type of substance at issue (and if applicable, approved by relevant governmental authority).
- ▶ Work in a well ventilated area.
- ▶ If the machine has an exhaust, direct the exhaust so as to reduce disturbance of dust in a dust filled environment.
- ▶ Operate and maintain the machine as recommended in the operating and safety instructions
- ▶ Select, maintain and replace consumables/ working tools/ other accessories as recommended in the operating and safety

instructions. Incorrect selection or lack of maintenance of consumables/ inserted tools/ other accessories may cause an unnecessary increase in dust or fumes.

- ▶ Wear washable or disposable protective clothes at the worksite, and shower and change into clean clothes before leaving the worksite to reduce exposure of dust and fumes to yourself, other persons, cars, homes, and other areas.
- ▶ Avoid eating, drinking, and using tobacco products in areas where there is dust or fumes.
- ▶ Wash your hands and face thoroughly as soon as possible upon leaving the exposure area, and always before eating, drinking, using tobacco products, or making contact with other persons.
- ▶ Comply with all applicable laws and regulations, including occupational health and safety regulations.
- ▶ Participate in air monitoring, medical examination programs, and health and safety training programs provided by your employer or trade organizations and in accordance with occupational health and safety regulations and recommendations. Consult with physicians experienced with relevant occupational medicine.
- ▶ Work with your employer and trade organization to reduce dust and fume exposure at the worksite and to reduce the risks. Effective health and safety programs, policies and procedures for protecting workers and others against harmful exposure to dust and fumes should be established and implemented based on advice from health and safety experts. Consult with experts.
- ▶ Residues of hazardous substances on the machine can be a risk. Before undertaking any maintenance on the machine, clean it thoroughly.

**▲ WARNING Overheated power pack**

The power pack can become overheated and cause burns.

- ▶ Never close the cooler in order to warm up the power pack quicker.
- ▶ Never run the power pack without a fan.

**▲ WARNING Slipping, tripping and falling hazards**

There is a risk of slipping, tripping or falling, for example tripping on hoses or on other objects. Slipping, tripping or falling can cause injury. To reduce this risk:

- ▶ Always make sure that no hose or other object is in your way or in any other person's way.
- ▶ Always make sure you are in a stable position with your feet as far apart as your shoulder width and keeping a balanced body weight.

#### ⚠ **DANGER Electrical hazard**

The machine is not electrically insulated. If the machine comes into contact with electricity, serious injuries or death may result.

- ▶ Never operate the machine near any electric wire or other source of electricity.
- ▶ Make sure that there are no concealed wires or other sources of electricity in the working area.

#### ⚠ **WARNING Involuntary start**

Involuntary start of the machine may cause injury.

- ▶ Keep your hands away from the start and stop device until you are ready to start the machine.
- ▶ Learn how the machine is switched off in the event of an emergency.
- ▶ Stop the machine immediately in all cases of power supply interruption.

#### ⚠ **WARNING Noise hazard**

High noise levels can cause permanent and disabling hearing loss and other problems such as tinnitus (ringing, buzzing, whistling, or humming in the ears). To reduce risks and prevent an unnecessary increase in noise levels:

- ▶ Risk assessment of these hazards and implementation of appropriate controls is essential.
- ▶ Operate and maintain the machine as recommended in these instructions.
- ▶ Select, maintain and replace the working tool as recommended in these instructions.
- ▶ If the machine has a silencer, check that it is in place and in good working condition.
- ▶ Always use hearing protection.
- ▶ Use damping material to prevent work pieces from 'ringing'.

#### ⚠ **WARNING Nominal pressure**

If the maximum nominal pressure for the hydraulic machine is exceeded, it can result in material damage and personal injury.

- ▶ Always run the hydraulic machine with a tool that does not require a continuously higher pressure than the stated nominal pressure. See section "Technical data".

## **Maintenance, precautions**

---

#### ⚠ **WARNING Machine modification**

Any machine modification may result in bodily injuries to yourself or others.

- ▶ Never modify the machine. Modified machines are not covered by warranty or product liability.
- ▶ Always use original parts, cutting blades/working tools, and accessories.
- ▶ Change damaged parts immediately.
- ▶ Replace worn components in good time.

#### ⚠ **WARNING Hot components**

Under normal working conditions the engine components, particularly the exhaust system, will get hot. The hydraulic oil, pump, valve, and tank can also reach high temperatures that can cause burns.

- ▶ Never touch a hot exhaust system, hydraulic oil, pump, valve or tank.

#### ⚠ **WARNING Accessory hazards**

Accidental engagement of accessories during maintenance or installation can cause serious injuries, when the power source is connected.

- ▶ Never inspect, clean, install, or remove accessories while the power source is connected.

## **Storage, precautions**

---

- ◆ Keep the machine and tools in a safe place, out of the reach of children and locked up.



## Overview

**To reduce the risk of serious injury or death to yourself or others, read the Safety instructions section found on the previous pages of this manual before operating the machine.**

## Design and function

PAC P9 is a hydraulic power pack designed for operating hydraulic breakers and other hydraulic machines. No other use is permitted.

PAC P9 is fitted with an 8,5 HP HONDA air cooled petrol engine with a hydraulic POD system (power on demand).

The oil flow is  $20 \pm 2$  l.p.m continuous (5 US gal/min).

## Main parts

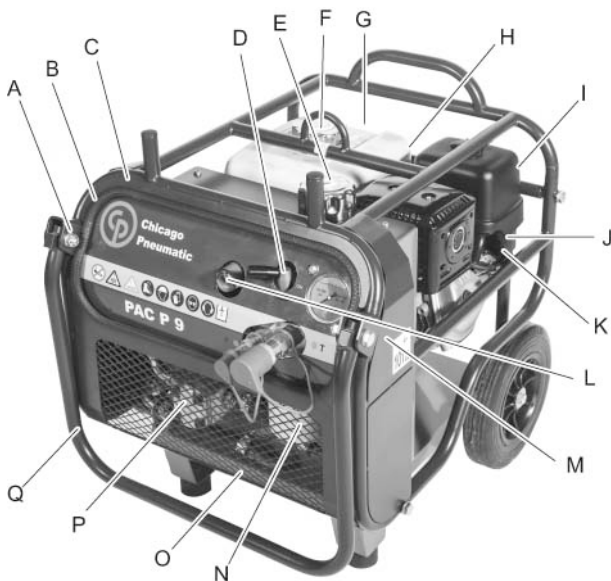

- A. Filter condition gauge
- B. Oil cooler
- C. Engine oil, dipstick
- D. By-pass valve
- E. Filler cap, hydraulic oil
- F. Filler cap, fuel
- G. Ignition switch OFF and ON
- H. Recoil start
- I. Air filter
- J. Choke control
- K. Fuel tap
- L. Sight glass, hydraulic oil level

- M. Pressure relief valve
- N. Hydraulic oil filter
- O. Drain plug
- P. Hydraulic pump
- Q. Foldable handles

## Labels

The machine is fitted with labels containing important information about personal safety and machine maintenance. The labels must be in such condition that they are easy to read. New labels can be ordered from the spare parts list.

### Data plate

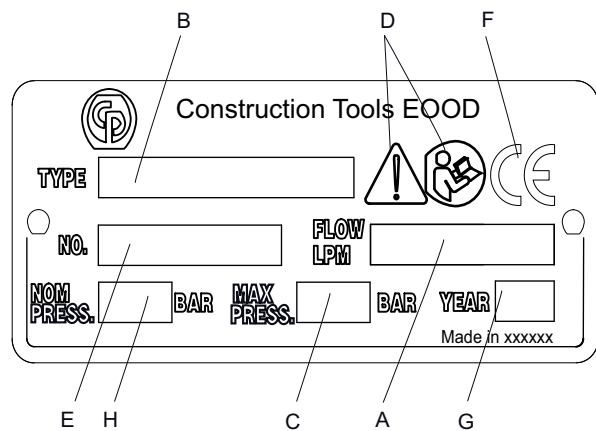

- A. Maximum permitted hydraulic oil flow
- B. Machine type
- C. Maximum relief valve setting
- D. The warning symbol together with the book symbol means that the user must read the safety and operating instructions before the machine is used for the first time.
- E. Serial number (is also stamped in the valve housing).
- F. The CE symbol means that the machine is EC-approved. See the EC declaration which is delivered with the machine for more information.
- G. Year of manufacture.
- H. Maximum nominal operating pressure

**Noise level label**

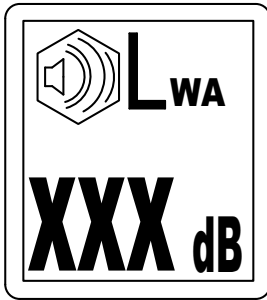

The label indicates the guaranteed noise level corresponding to EC-directive 2000/14/EC. See "Technical data" for accurate noise level.

**EHTMA**

The European Hydraulic Tool Manufacturers Association (EHTMA) has categorised hydraulic power packs and tools in terms of flow rate and working pressure.

	<b>PAC P9</b>
Flow rate	20 l.p.m. (5 US gal/min)
Nominal pressure	125 bar (1,810 psi)
Max pressure	150 bar (2,175 psi)
EHTMA category	C

**EHTMA category**

The machine is clearly marked with EHTMA categories. It is important that any power source used is in a compatible category. If any doubt, consult an authorised supervisor.



**Safety label**



**Fuel label**

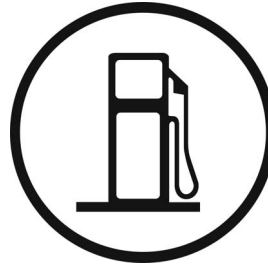

**Lifting point label**

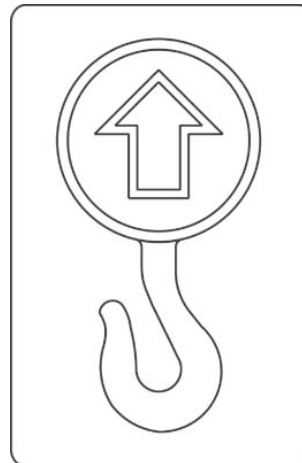

**Installation**

**▲ WARNING Whipping hydraulic hose**

Hydraulic hoses under pressure can whip uncontrollably if screws loosen or are loosened. A whipping hydraulic hose can cause severe injuries.

- ▶ Depressurise the hydraulic system before loosening the connection of a hydraulic hose.
- ▶ Tighten the nuts on the connections of the hydraulic hoses to the required torque.
- ▶ Check that the hydraulic hose and the connections are not damaged.

**Quick-release couplings**

The original hydraulic hoses are fitted with Flat-Face quick-release couplings that are strong and easy to clean. The quick-release couplings are fitted so that the male connection supplies oil and the female connection receives oil.

*NOTICE* Wipe all couplings clean before connecting. Ensure that couplings are clean and correctly engaged before operation. Failure to do so may result in damage to the quick couplings and cause overheating and cause foreign matter to enter the hydraulic system.

## Hydraulic oil

In order to protect the environment, use of biologically degradable hydraulic oil is recommended. No other fluids must be used.

- ◆ Viscosity (preferred) 20-40 cSt.
- ◆ Viscosity (permitted) 15-100 cSt.
- ◆ Viscosity index minimum 100.

Standard mineral or synthetic oil can be used. Make sure to only use clean oil and filling equipment.

When the machine is used continuously, the oil temperature will stabilise at a level which is called the working temperature. This will, depending on the type of work and the cooling capacity of the hydraulic system, be between 20-40°C (68-104°F) above the ambient temperature. At working temperature, the oil viscosity must be within the preferred limits. The viscosity index indicates the connection between viscosity and temperature. A high viscosity is therefore preferred, because the oil can then be used within a wider temperature range. The machine must not be used, if oil viscosity fails to remain within the permitted area, or if the working temperature of the oil does not fall between 20°C (68°F) and 70°C (158°F).

**NOTICE** The setting of the pressure relief valve on the machine can in some cases be higher than the prescribed maximum setting according to the EHTMA category, see "EHTMA category". A too high pressure relief valve setting can harm the machine to be used. Readjust the pressure relief valve, if the technical specifications of the machine prescribe a lower pressure relief valve setting than the standard setting of the machine.

## Hydraulic control and connectors



The by-pass valve (A) must be in the OFF position when starting and in the ON position when using the machine.

Connectors (B) and (C) are used to connect the power pack to the machine as follows:

- ◆ Connector (B) = Return (female quick-release coupling).
- ◆ Connector (C) = Feed (male quick-release coupling).

## Hoses and connections

Ensure that the machine you plan to use is compatible with the model of power pack being used. Otherwise, both the power pack and the machine might be harmed. Check the "Technical data" in this instruction book and compare the flow rate with the technical specifications in the instruction book for the machine.

### Connecting hoses

1. Turn the by-pass valve to the OFF position and stop the engine.
2. Make sure the couplings are clean and serviceable.
3. Attach the return line hose and the feed line hose.
4. Start the engine and run the power pack to fill up the hydraulic circuit. Check the hydraulic oil level.

### Disconnecting hoses

1. Turn the by-pass valve to the OFF position and stop the engine.
2. Remove the feed line hose and the return line hose.

The couplings are unlocked by moving the collar back on the coupling.

### Hose length

For power packs giving a flow of 20 l.p.m. (5 US gal/min), a maximum hose length of 21 m (69 ft) is recommended. For power packs giving a higher flow, a maximum hose length of 14 m (46 ft) is recommended.

Normally, 7 m (23 ft) of Twin hose is used for the power pack.

Twin hoses and other accessories are shown in the spare parts list.

## Checking the hydraulic system

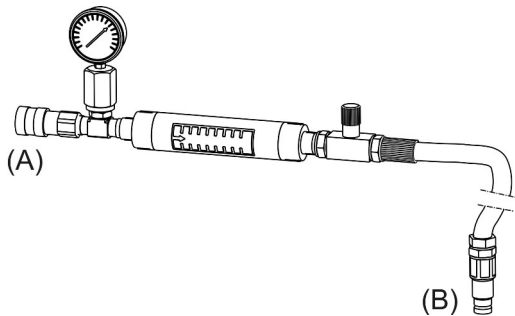

To set or check the hydraulic oil flow and the pressure relief valve we recommend using Chicago Pneumatic or similar test equipment.

- ◆ 0-250 bar (0-3,600 psi)
  - ◆ 5-46 l.p.m. (1-12 US gal/min)
1. Stop the engine.
  2. Connect the test equipment to the power pack. Male (B) to the return connector and female (A) to the feed connector on the power pack.
  3. Make sure that the test equipment loading valve is fully open.
  4. Start the engine.
  5. Move the by-pass valve on the power pack to the on position.
  6. Turn the loading valve, until the gauge shows approximately 70 bar (1,000 psi) and allow the power pack to warm up for 3-4 minutes.
  7. Slowly close the loading valve, until the pressure gauge shows a pressure of 100 bar (1,400 psi).

8. Check that the flow is according to the flow rate in the technical specifications.
9. The accuracy of the reading on the flow meter is  $\pm 2$  l.p.m. ( $\pm 0.5$  US gal/min). If the performance is not in accordance with the technical specifications for the power pack, see section "Troubleshooting".

## Transport

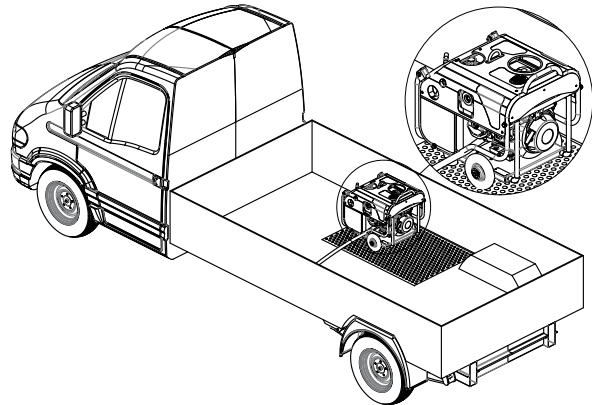

During transport make sure the power pack is secured. Ensure that the power pack is upright during transportation and lifted with approved lifting equipment.

## Operation

### ▲ WARNING Involuntary start

Involuntary start of the machine may cause injury.

- ▶ Keep your hands away from the start and stop device until you are ready to start the machine.
- ▶ Learn how the machine is switched off in the event of an emergency.
- ▶ Stop the machine immediately in all cases of power supply interruption.

## Operating

### Preparation before starting

The following checks must be made each time you start to use the power pack. All these checks concern the serviceability of the power pack. Some concern your safety:

- ◆ Clean all safety labels. Replace any that are missing or cannot be read.
- ◆ Inspect the power pack and hoses generally for signs of damage.

- ◆ Ensure that the by-pass valve moves freely. For maintenance see "Every day".
- ◆ Remove dirt and debris especially from the linkages and hydraulic oil cooler.
- ◆ Check for oil and fuel leakages beneath the power pack.
- ◆ Ensure that the hydraulic couplings are clean and fully serviceable.
- ◆ Check all fastenings.
- ◆ Check the hydraulic oil level and add as necessary.
- ◆ Check the engine oil level and add oil as necessary.
- ◆ Make sure the fuel filler cap is tightly closed.
- ◆ Place the power pack in a safe position, to prevent tilting during operation.
- ◆ Ensure that any machines you plan to use are compatible with the power pack model used.
- ◆ Ensure that you have adequate fuel for the job. Top up as necessary, taking care not to overfill.
- ◆ If the power pack has a recoil starter for starting the engine, the cord must not be wound around the operator's hand when starting the engine.

The first time the power pack is started with new hoses, these will take approx 1.5 litres (0.4 US gal) of oil to fill up. Add this amount of oil after the first start-up.

## Start and stop

### Starting the engine

1. Turn the engine switch (A) to position ON.

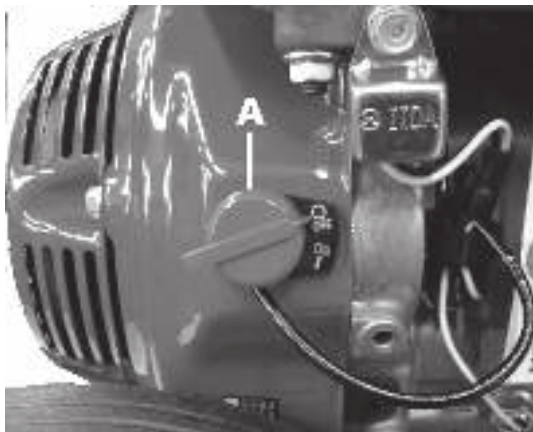

2. Turn on the fuel by setting the fuel control (B) to the ON position.

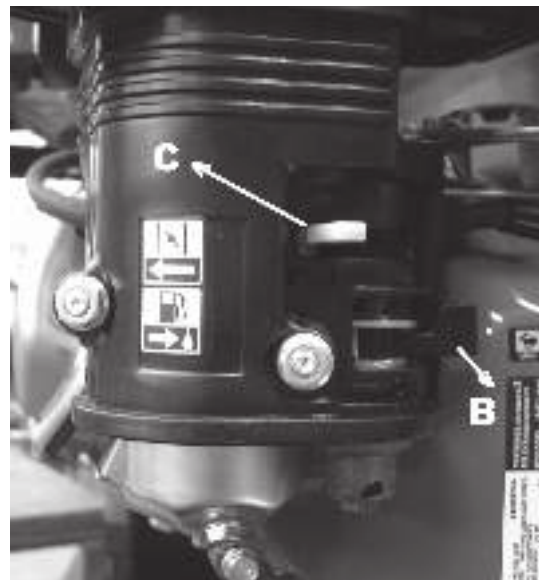

3. Move the choke control (C) to the CLOSE position. If the engine is warm, or the air temperature is high, move the choke control to the OPEN position.
4. Set the hydraulic by-pass valve (D) to the OFF position.



5. Pull out the starter cord (E) until it resists. Release the handle so the starter cord goes back again, and then pull the starter cord until the engine starts.

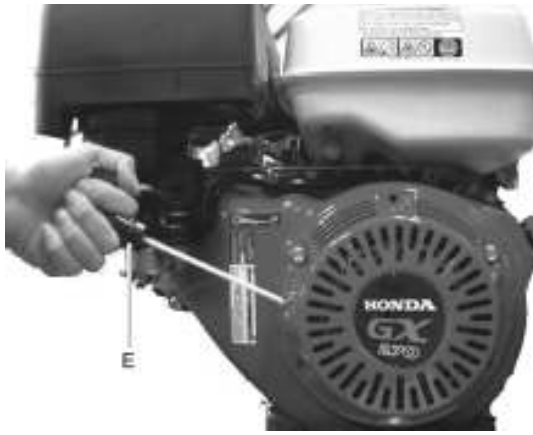

6. As the engine warms up, gradually move the choke control (C) to the OPEN position. Before usage, the power pack must be allowed to warm up to its working temperature for several minutes.

### Stopping the engine

1. Turn the engine switch (A) to position OFF.
2. Turn off the fuel by setting the fuel control (B) to the OFF position.

### When taking a break

- ◆ During all breaks you must place the machine in such a way that there is no risk for it to be unintentionally started. Make sure to place the machine on the ground, so that it can not fall.
- ◆ Switch off the power supply in the event of a longer break or when leaving the workplace.

### Maintenance

Regular maintenance is a basic requirement for the continued safe and efficient use of the machine. Follow the maintenance instructions carefully.

- ◆ Before starting maintenance on the machine, clean it in order to avoid exposure to hazardous substances. See “Dust and fume hazard”.
- ◆ Use only authorised parts. Any damage or malfunction caused by the use of unauthorised parts is not covered by warranty or product liability.
- ◆ When cleaning mechanical parts with solvent, comply with appropriate health and safety regulations and ensure there is satisfactory ventilation.
- ◆ For major service of the machine, contact the nearest authorised workshop.

- ◆ After each service, check that the machine's vibration level is normal. If not, contact the nearest authorised workshop.

### Every day

Never perform maintenance when the power pack is running.

- ◆ Clean and inspect the machine and its functions each day before start working.
- ◆ Conduct a general inspection for leaks and damage and wear.
- ◆ Disassemble the by-pass valve and clean it, replace the o-ring if worn.
- ◆ Change damaged parts immediately.
- ◆ Replace worn components in good time.
- ◆ Never use the equipment if you suspect that it is damaged.
- ◆ Never strike or abuse the equipment.
- ◆ Make sure that all the attached and related equipment, such as hoses and POD (power on demand) are in good condition.
- ◆ Check hydraulic oil level.
- ◆ Check hydraulic couplings.
- ◆ Check hydraulic filter.
- ◆ Check engine oil level.
- ◆ All fasteners and other threaded components to be tightened to the specified torque only.
- ◆ Check tightness of nuts, bolts, screws and hose fittings after the first days of operation and there after in accordance with the maintenance schedule.
- ◆ The engine oil should be replaced after the first 8 hours of operation and thereafter in accordance with the maintenance schedule in the engine manufacturer's operating and maintenance instructions.

### Check hydraulic oil filter

When the filter gauge needle remains in the red sector (while the engine is idling and the oil is at service temperature), the filter must be replaced.

1. Stop the engine, switch off by-pass valve.
2. The old filter is removed by turning it clockwise (use a filter strap wrench if necessary).
3. Tilting the power pack rearwards will minimise oil spillage.
4. Before mounting the new filter, it is recommended to grease the surface of the seal with oil in order to ease tightening of the filter.



## Every three months

---

- ◆ Check tightness of nuts, bolts, screws and hose fittings.
- ◆ Clean the air cleaner element, see engine manufacturer's handbook.

## Every 300 hours or every year

---

- ◆ Change the hydraulic oil.
- ◆ Wash the hydraulic tank.
- ◆ Change the hydraulic oil filter.
- ◆ For engine maintenance, see engine manufacturer's handbook.

## Storage

- ◆ Empty the tank before storing the machine.
- ◆ Check that the machine is properly cleaned before putting it away for storage.
- ◆ Store the machine in a dry place.
- ◆ We recommend to store the machine in a standing position. If stored in a lying position, the machine must be placed on the back cover.
- ◆ Keep the machine and tools in a safe place, out of the reach of children and locked up.

## Disposal

A used machine must be treated and disposed of in such a way that the greatest possible portion of the material can be recycled and any negative influence on the environment is kept as low as possible, and in respect to local restrictions.

Before a petrol driven machine is deposited it must be emptied and cleaned of all oil and petrol. Remaining oil and petrol must be dealt with in a way that does not affect the environment.

# Troubleshooting

Problem	Cause	Solution
Engine turns over but does not start	No fuel	Top up tank
	Fuel line blocked	Clear line
	Fuel tap in position OFF	Turn tap to position ON
	Choke not closed	Close choke
	Engine malfunction	Consult engine manual
	Engine oil level drop	Check oil level with dipstick, add if necessary
Engine does not turn over or is difficult to turn	By-pass valve in the ON position	Turn valve to OFF
	Engine malfunction	Consult engine manual
Low hydraulic oil level	Damaged hoses	Check and replace if necessary
	Leaking connections	Check for tightness/leaks
	Defective hose couplings	Replace couplings
Poor machine performance	Low pressure relief valve setting	Adjust valve
	High back pressure	Check hose system for blockage
	Worn hydraulic pump	Replace pump
Frothy or creamy coloured hydraulic oil	Air or water in oil	Check for loose connections on line to pump
		Make sure that the filler cap on the tank is not loose
		Check that oil level is at the top of the sight glass
Machine runs hot	Poor siting of power pack causing warm air to recirculate	Resite power pack for free air circulation
	Blocked oil cooler	Blow cooler clean. NEVER use a wire brush
	Defective fan	Replace fan
	Back pressure too high	Check hose system
	Machine defective	Check and service the machine
Power pack stops suddenly	Out of fuel	Top up tank
	Working at low rpm	Make sure that hydraulic oil has reached its working temperature
	Engine oil level drop	Check oil level with dipstick, add if necessary



## Technical data

### Machine data

	PAC P9
Height, mm (in.)	640 (25,2)
Width, mm (in.)	530 (20,9)
Length, mm (in.)	630 (24,8)
Temperature range, °C (°F)	-20 to 40 (-4 to 104)
Weight incl oil, kg (lb)	80 (176,4)
Flow, l/m (US gal/min)	20 (5)
EHTMA category	C
Nominal pressure, bar (psi)	125 (1,810)
Standard pressure setting, bar (psi)	150 (2,175)
Circuit type	Open centre
Pump type	Gear pump, directly driven from the motor shaft by means of a flexible coupling.
Oil tank capacity, litres (US gal)	8 (1,76)
Filtration	25µ filter in return line. Filter by-pass valve in valve block.
Cooling system	Thermostatically controlled air blast oil cooler.
Motor type	Honda GX 270 QX, air cooled, 1 cylinder 4-stroke petrol engine with oil alert system and transistor ignition system.
Performance, HP (kW)	8,5 (6,3) at 3,600 r.p.m.
Fuel	Unleaded petrol. A minimum of 87 octane/87 AKI (91 RON).
Engine oil	Consult engine manual
Fuel tank capacity, litres (US gal)	6 (1,32)
Starter	Recoil start

### Noise declaration statement

Guaranteed sound power level **L<sub>w</sub>** according to EN ISO 3744 in accordance with directive 2000/14/EC.

Sound pressure level **L<sub>p</sub>** according to EN ISO 11203.

These declared values were obtained by laboratory type testing in accordance with the stated directive or standards and are suitable for comparison with the declared values of other tools tested in accordance with the same directive or standards. These declared values are not suitable for use in risk assessments and values measured in individual work places may be higher. The actual exposure values and risk of harm experienced by an individual user are unique and depend upon the way the user works, in what material the machine is used, as well as upon the exposure time and the physical condition of the user, and the condition of the machine.

We, Construction Tools EOOD, cannot be held liable for the consequences of using the declared values, instead of values reflecting the actual exposure, in an individual risk assessment in a work place situation over which we have no control.

## Noise data

<b>Noise</b>			
	<b>Sound pressure</b>	<b>Sound power</b>	
	<b>Declared values</b>		
	<b>EN ISO 11203</b>	<b>2000/14/EC</b>	
<b>Type</b>	<b>Lp r=1m dB(A) rel 20µPa</b>	<b>Lw guaranteed dB(A) rel 1pW</b>	<b>Uncertainties, sound value dB(A)</b>
PAC P9	87	101	1.2

# EC Declaration of Conformity

## EC Declaration of Conformity (EC Directive 2006/42/EC)

We, Construction Tools EOOD, hereby declare that the machines listed below conform to the provisions of EC Directive 2006/42/EC (Machinery Directive) and 2000/14/EC (Noise Directive), and the harmonised standards mentioned below.

Hydraulic power packs	Guaranteed sound power level [dB(A)]	Measured sound power level [dB(A)]
PAC P9	101	99

### Following harmonised standards were applied:

◆ -

### Following other standards were applied:

- ◆ ISO 4413-ed3 2010-11-15
- ◆ BS EN 60204-1 2006 + A1 2009-04-30
- ◆ 2014/30/EU
- ◆ 73/23/EEC

### Technical Documentation authorised representative:

Emil Alexandrov  
Construction Tools EOOD  
7000 Rousse  
Bulgaria

### General Manager:

Stijn Verherstraeten

### Manufacturer:

Construction Tools EOOD  
7000 Rousse  
Bulgaria

### Place and date:

Rousse, 2017-01-31



**Chicago  
Pneumatic**

**2017-01-31 | No. 3392 5255 01**

© Construction Tools EOOD