

# MOTOMAN AR1730

Arc Welding with the AR-series



The powerful, dynamic six-axis MOTOMAN AR1730 robot provides highest motion performance in its class to achieve optimal results in extremely difficult conditions and especially for the high demands of arc welding applications.

With a high payload of up to 25 kg and a wide working range of 1730 mm this robot supports welding of bulky workpieces and mounting a broad variety of heavy welding and cutting equipment.

Its hollow arm design enables leading the welding cables and wire feeding through the arm to the wrist, which saves valuable space around it. The MOTOMAN AR1730 allows easy programming and enables high freedom of motion.

The wire feeder can be mounted in the prepared space at axis 3, supporting short distance and centric supply of the welding wire to the weld torch. The streamlined, slightly bowed arm structure reduces the interference area between the jigs and work pieces.

## KEY BENEFITS

- Powerful and dynamic
- Wide motion range
- High path accuracy
- Easy programming
- Less interferences due to optimized design

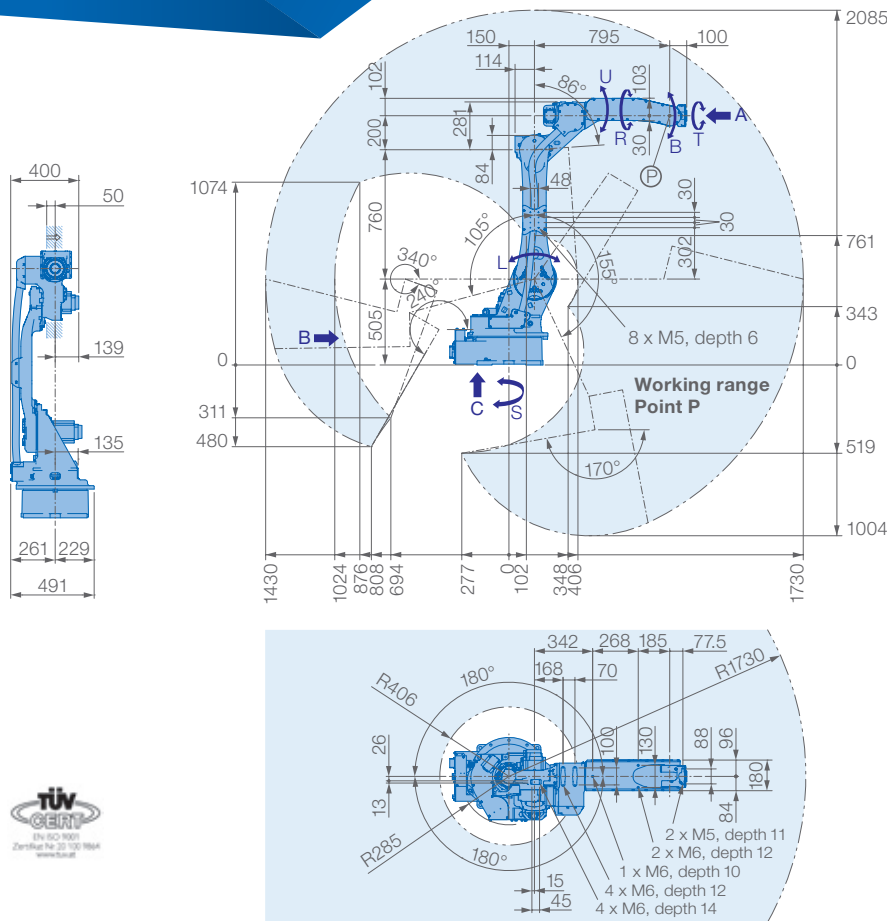

**View A**

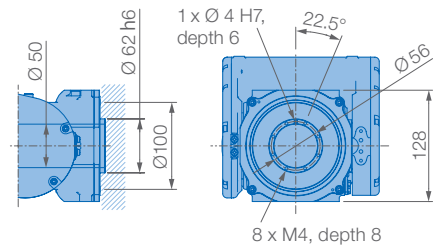

**View B**

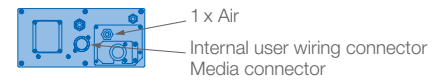

**View C**

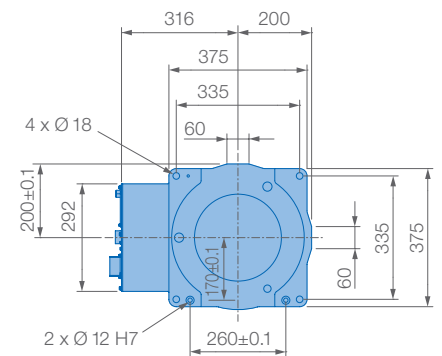

**Allowable wrist load**

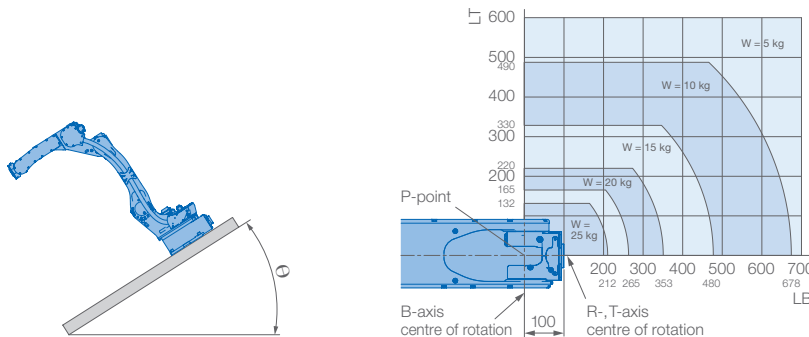

Mounting options: Floor, ceiling, wall, tilt\*

Protection class: Main axes (S, L, U) IP54 (option IP65), wrist IP67

\* tilt with condition of angle – see table below

Robot installation angle $\theta$ [deg.]	S-axis operating range [deg.]
$0 \leq \theta \leq 30$	$\pm 180$ degrees or less (no limit)
$30 < \theta \leq 35$	$\pm 60$ degrees or less
$35 < \theta$	$\pm 30$ degrees or less

Specifications AR1730						
Axes	Maximum motion range [°]	Maximum speed [°/sec.]	Allowable moment [Nm]	Allowable moment of inertia [kg · m <sup>2</sup> ]	Controlled axes	6
S	$\pm 180$	210	–	–	Max. payload [kg]	25
L	+155/–105	210	–	–	Repeatability [mm]	$\pm 0.06^*$
U	+160/–86	265	–	–	Max. working range R [mm]	1730
R	$\pm 200$	420	52	2.3	Temperature [°C]	0 to +45
B	$\pm 150$	420	52	2.3	Humidity [%]	20 – 80
T	$\pm 455$	885	32	1.2	Weight [kg]	250
					Power supply, average [KVA]	2,0**

\* Conforms to ISO 9283 \*\* Varies in accordance with applications and motion patterns

**YASKAWA Europe GmbH**

Robotics Division  
Yaskawastraße 1  
85391 Allershausen  
Germany

Tel. +49 (0) 8166 90-0  
robotics@yaskawa.eu.com  
www.yaskawa.eu.com

YR-1-25VX12-A00  
A-09-2019, A-No. 207078