

YASKAWA

MOTOMAN AR2010

Arc Welding with the AR-series



The 6-axis robot MOTOMAN AR2010 of our AR series, thanks to its high path accuracy, is an optimal robot for arc welding applications.

With a payload of up to 12 kg and a wide working range of 2010 mm this robot supports welding of bulky workpieces.

Its hollow arm design enables leading the welding cables and wire feeding through the arm to the wrist, which saves valuable space around it. The MOTOMAN AR2010 allows easy programming and enables high freedom of motion.

The wire feeder can be mounted in the prepared space at axis 3, supporting short distance and centric supply of the welding wire to the weld torch. The streamlined, slightly bowed arm structure reduces the interference area between the jigs and work pieces.

The robot is controlled by the YRC1000 controller which facilitates both programming and use with a wide range of functions specially designed for arc welding applications.

KEY BENEFITS

- Wide motion range
- High path accuracy
- Easy programming
- Less interferences due to optimized design

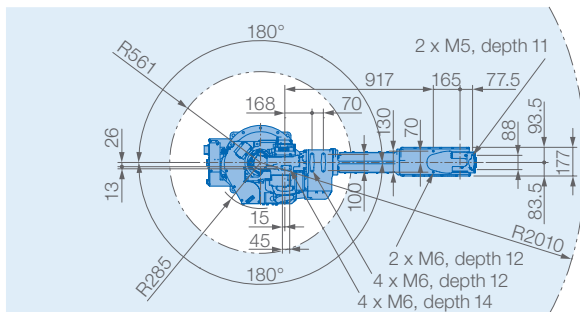
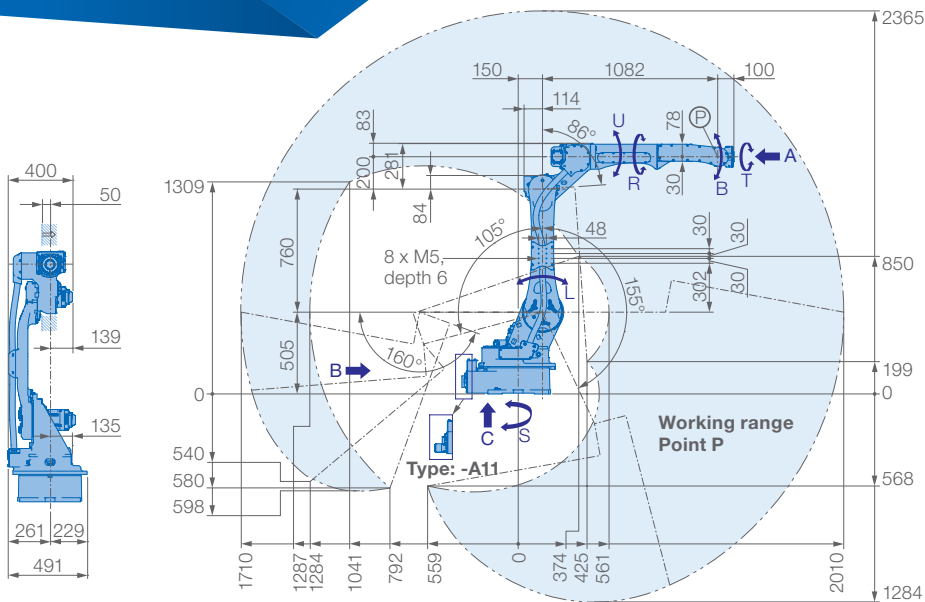

View A

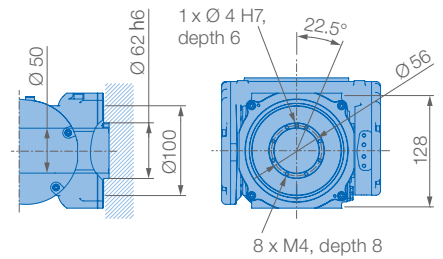

View B

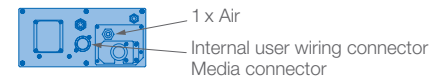

View C

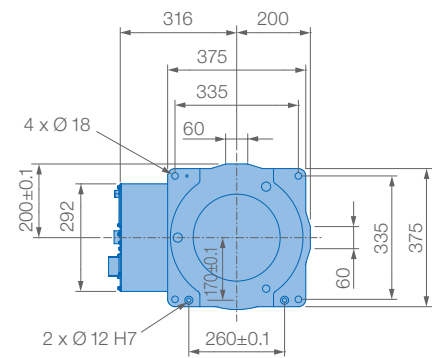

Mounting options: Floor, ceiling, wall, tilt*
 Protection class: Main axes (S, L, U) IP54, wrist IP67

* tilt with condition of angle – see table below

Robot installation angle θ [deg.]	S-axis operating range [deg.]
$0 \leq \theta \leq 30$	± 180 degrees or less (no limit)
$30 < \theta \leq 35$	± 60 degrees or less
$35 < \theta$	± 30 degrees or less

Allowable wrist load

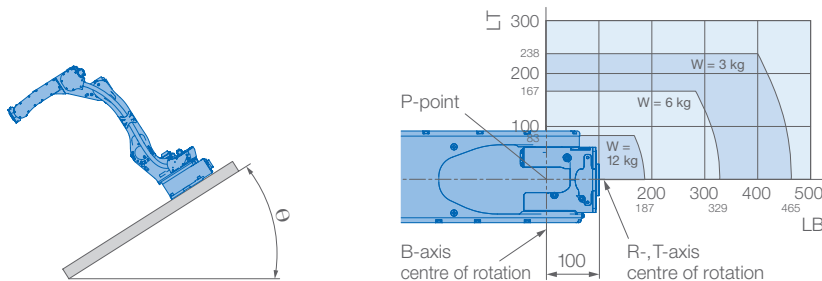

Specifications AR2010

Axes	Maximum motion range [°]	Maximum speed [°/sec.]	Allowable moment [Nm]	Allowable moment of inertia [kg · m ²]	Controlled axes	6
S	± 180	210	–	–	Max. payload (on U-axis) [kg]	12 (9)
L	$+155/-105$	210	–	–	Repeatability [mm]	$\pm 0.08^*$
U	$+160/-86$	220	–	–	Max. working range R [mm]	2010
R	± 200	435	22	0.65	Temperature [°C]	0 to +45
B	± 150	435	22	0.65	Humidity [%]	20 – 80
T	± 455	700	9.8	0.17	Weight [kg]	260
					Power supply, average [KVA]	2.0**

* Conforms to ISO 9283 ** Varies in accordance with applications and motion patterns

YASKAWA Europe GmbH

Robotics Division
 Yaskawastraße 1
 85391 Allershausen
 Germany

Tel. +49 (0) 8166 90-0
 robotics@yaskawa.eu.com
 www.yaskawa.eu.com

YR-1-25VX12-A00
 A-12-2019, A-No. 207080