



Design, manufacture, sales & service of
pneumatic tools

PERMON s.r.o.
Roztoky
27023 Křivoklát
CZECH REPUBLIC

tel: +420 (0)313 558145
+420 (0)313 558271-4
fax: +420 (0)313 558313
email: export@permon.cz
www.permon.cz

SEIT 1826 - SINCE 1826

OPERATION AND MAINTENANCE MANUAL

VK 23



**IMPORTANT SAFETY INFORMATION ENCLOSED. READ THIS MANUAL BEFORE
OPERATING TOOL.**

**IT IS THE RESPONSIBILITY OF THE EMPLOYER TO PLACE THE INFORMATION IN
THIS MANUAL INTO THE HANDS OF THE OPERATOR.**

FAILURE TO OBSERVE THE FOLLOWING WARNINGS COULD RESULT IN INJURY.

VK23 rock drill is designed for drilling through low to high strength materials in connection to an air leg. The medium weight tool can be used for drilling holes during blasting operations in mines as well as on road construction sites and other utility work. The recommended drilling range is 6 – 8 m with a diameter of 45 mm or 1 – 2 m with a diameter of 62 mm.

Permon is not responsible for any customer's modifications of tools for applications on which Permon was not consulted.

PLACING TOOL IN SERVICE

- Always operate, inspect and maintain this tool in accordance with all regulations (local, state, federal and country), that may apply to hand held/hand operated pneumatic tools.
- For safety, top performance and maximum durability of parts, operate this tool at 4 – 6 bar/400 – 600 kPa maximum air pressure at the inlet with 1" (25 mm) inside diameter air supply hose. Apply the optimal thrust of 150 – 200 N.
- Keep the water flushing pressure at roughly 100 kPa less than the operating air pressure. The water consumption is approximately 240 litres per hour.
- Always turn off the air supply and disconnect the air supply hose before installing, removing or adjusting any accessory on this tool, or before performing any maintenance on this tool.
- Do not use damaged, frayed or deteriorated air hoses and fittings.
- Be sure all hoses and fittings are of the correct size and are tightly secured.
- Always use clean, dry lubricated air at 6 bar/600 kPa maximum air pressure. Dust, corrosive fumes and/or excessive moisture can ruin the motor of an air tool.
- Do not lubricate tools with flammable or volatile liquids such as kerosene, diesel or jet fuel.
- Do not remove any labels. Replace any damaged label.
- Carrying out a check-up of the tool after 150 – 200 hours of operation is recommended.

USING THE TOOL

- Always wear eye protection when operating or performing maintenance on this tool.
- Always wear hearing protection when operating this tool.
- Keep hands, loose clothing and long hair away from the rotating end of this stool.
- Anticipate and be alert for sudden changes in motion during every start up and operation of any power tool.
- Keep your body stance balanced and firm. Do not overreach when operating this tool.
- Tool accessories may continue to impact briefly after throttle is released.
- Air powered tools can vibrate in use. Vibration, repetitive motions or uncomfortable positions may be harmful to your hands and arms. Stop using any tool if discomfort, tingling feeling or pain occurs. Seek medical advice before resuming use.
- Use accessories recommended by Permon.
- This tool is not designed for working in explosive atmospheres.
- This tool is not insulated against electric shock.

The use of other than genuine Permon replacement parts may result in safety hazards, decreased tool performance, and increased maintenance, and may invalidate all warranties.

Repairs should only be executed by an authorised trained personnel. Consult your nearest Permon authorised service centre.

SPECIFIC WARNINGS

- Always wear eye protection when operating or performing maintenance on this tool.
- Always wear hearing protection when operating this tool.
- Always turn off the air supply and disconnect the air supply hose before installing, removing or adjusting any accessory on this tool, or before performing any maintenance on this tool.
- Do not use damaged, frayed or deteriorated air hoses and fittings.
- Air powered tools can vibrate in use. Vibration, repetitive motions or uncomfortable positions may be harmful to your hands and arms. Stop using any tool if discomfort, tingling feeling or pain occurs. Seek medical advice before resuming use.
- Do not carry the tool by the hose.
- Keep your body stance balanced and firm. Do not overreach while operating this tool.
- Operate at a maximum of 6.0 bar/600 kPa air pressure.
- When wearing gloves and operating models with an inside trigger, always make sure that the gloves will not prevent the trigger from being released.
- Wear safety shoes, a hard hat, safety goggles, gloves, a dustmask and any other appropriate protective clothing while operating the tool.

- Do not indulge in horseplay. Distraction can cause accidents.
- Keep hands and fingers away from the throttle lever until it is time to operate the tool.
- Never rest the tool or drill steel on your foot.
- Never point the tool at others.
- Compressed air is dangerous. Never point an air hose at other people or yourself.
- Never use compressed air to blow clothes free of dust.
- Be sure all the hose connections are tight. A loose hose not only leaks but can come completely off of a tool and, while whipping under pressure, injure the operator and others in the area. Attach safety cables to all hoses to prevent injury in case a hose is accidentally broken.
- Never disconnect a pressurised air hose. Always turn off the air supply and bleed the tool before disconnecting a hose.
- The operator must keep limbs and body clear of the drill steel. If a drill steel breaks, the tool with the broken drill steel projecting from the tool will suddenly surge forward.
- Do not ride the tool with one leg over the handle. An injury can occur if the drill steel breaks while riding the tool.
- Learn what is underneath the worked material. Be alert for hidden water, gas, sewer, telephone or electric lines.
- To clean any parts of the rock drill, only use proper cleaning solvents that meet current safety and health standards. Use the cleaning solvents in a well-ventilated area.
- Do not flush the tool or clean any of its parts using diesel fuel. Diesel fuel residue will ignite as the tool is operated, causing damage to its internal parts. While using models with outside triggers or throttle levers, take care to prevent accidental operation when laying the tool down.
- Do not operate a tool with broken or damaged parts.
- Never start a tool while it is lying on the ground.
- This tool is not designed for working in explosive atmospheres.
- This tool is not insulated against electric shock.

OPERATION

Lubrication

Always use an air line lubricator with these tools.

Recommended environmentally friendly oils:

TOTAL PNEUMA

SHELL TORCULA 32

Top Oil BIO Uni
Atea PNEU-EKO

Recommended mineral oil:
PARAMO PNEUMAT 46

Attach the lubricator as close to the tool as practical. Use the recommended LR-1 oiler or the SOOR 6 unit to ensure sufficient lubrication. If an air line lubricator is not available, disconnect the air hose and pour about 0.5 dcl / 50 ccm of oil into the air inlet and 0.1 dcl / 10 ccm into the supply elbow of the tool at the beginning of each work shift. Repeat after every 30 minutes of operating the machine.

For operating multiple drilling hammers at one work site, usage of the SOOR unit (for 3 hammers) or the distribution frames R4 (for 4 hammers) or R5 (for 5 hammers) is recommended.

Before storing the tool or if the tool is to be idle for a period exceeding 3 weeks, pour about 0.5 dcl / 50 ccm of oil into the air inlet and operate the tool shortly to coat the internal parts with oil.

Lubricate the fronthead regularly (beginning of each shift) with a water resistant grease (use grease nipple).

Do not use any of the environmentally friendly oils for conservation.

Air Supply and Connections

Always use clean, dry lubricated air. Dust, corrosive fumes and/or excessive moisture can ruin the motor of an air tool. An air line filter can greatly increase the life of an air tool. The filter removes dust and moisture.

Make sure all hoses and fittings are tightly secured and of the correct size.

Water Supply and Connections

Always use clean water. Make sure all hoses and fittings are tightly secured and of the correct size.

Air Leg Installation

Connect the air leg to the yoke of the hammer and firmly tighten the cap nut. Check regularly during the operation.

Accessory Installation

Always turn off the air supply and disconnect the air supply hose before installing, removing or adjusting any accessory on this tool or before performing any maintenance on this tool. Failure to do so could result in an injury.

1. Open the retainer.
2. Insert the drill rod into the hammer.
3. Close the retainer.

- Do not repair the tool at the work site. Always take the tool to a repair shop. Never drag the tool on the ground. The air port and other openings will become clogged with dirt and debris.
- Compressed air is dangerous. Avoid pointing the hose at any of your co-workers or yourself and never use the air to clear the worksite or work clothing.
- Do not operate the tool unless the drill steel is pushed against the worked material to avoid premature wear of parts and reduce the vibration isolation properties of the tool.

The starting lever has 4 positions:

- 1/ The starting lever is perpendicular to the hammer axis – STOP
- 2/ The starting lever is 45 degrees forwards – SLOW DRILLING
- 3/ The starting lever is forwards parallel with the hammer axis – FULL DRILLING OUTPUT
- 4/ The starting lever is backwards – FLUSHING THE HOLE

SPECIFICATIONS

Weight	<i>kg</i>	26,5
Length	<i>mm</i>	720
Height	<i>mm</i>	285
Working Pressure	<i>bar</i>	4 – 6
Air Consumption	<i>m³/min</i>	4
Impacts per Revolution	–	16
Impact rate	<i>1/min</i>	2100
Chuck Size	<i>mm</i>	hex. 22X108
Air Supply Hose	<i>mm</i>	25
Water Supply Hose	<i>mm</i>	13
Torque	<i>Nm</i>	16

DISASSEMBLING THE VK23 ROCK DRILL

GENERAL INSTRUCTIONS

- Clean the outer surface of the rock drill.
- Do not disassemble the rock drill any further than necessary to replace or repair damaged or worn parts.
- Whenever grasping the rock drill in a vice, always use leather or copper covered vice jaws to protect the surface of the part and help to prevent distortion. Take extra care with threaded parts and housings.
- Do not remove any part that is a press fit in or on a subassembly unless the removal of the part is necessary for repairs or replacement.
- Do not disassemble the rock drill unless a complete set of seals and o-rings is available for replacement.

All components are hold together by 2 side bolts (33). Screw out the nuts (34), remove side bolts (33) and handle (32).

Remove the cylinder cover (51) step by step with the stirrup (52) and drill bushing (49), impact sleeve (46), piston (2) with the tang nut (44), cylinder (1) with the pin (60), bottom distribution cover (42) with the stop (47), distribution body (41), upper distribution cover (40), distribution ring (43), ratchet (39) with the screw driving lug (35), pawls (36), pins (37) and springs (38).

Warning! The threads of the tang nut (44) and the carrier (50) are left-handed!

Disassembly of the flushing valve:

Screw off the plug (20) with the ring (19) from the cylinder head (3). Remove the spring (23), starting rod (16) and the starting pin (15). If necessary, remove inner piece (14) with rings (17, 18).

Disassembly of the starting lever and air inlet:

Press out the pins (7) and remove balls (6) through the free holes – 20 pieces on the starting lever, 21 pieces on the air inlet (8). Remove the starting lever and the air inlet.

Remove the arresting pin (5) and spring (4) from the starting lever.

Disassembly of the flushing pipes:

Screw out the nut (31) and the plug (30), remove the sealing (28), the inner piece (29), the water flushing pipe (25) with its sealing (28), inner piece (27) and the air flushing pipe (26).

Disassembly of the air leg stirrup:

Press in the pin (58), remove ring (54) from the pin (57). Pull out the pin (58) and spring (55) from the pin (57).

Press out the pin (57) from the cylinder and release the stirrup (53).

ASSEMBLY OF THE VK23 ROCK DRILL

GENERAL INSTRUCTIONS

- Before assembling the rock drill, clean all the parts thoroughly, dry them up and carefully inspect for signs of wear.
- Lubricate all moving parts with the recommended oil (see Lubrication).
- Replace all the rubber parts and plastic pins (7) – if removed.
- Apply a thin film of O-ring lubricant to all O-rings before final assembly.

Assembly is made the opposite way to disassembly. When inserting the distribution body (41) be careful not to place it facing in the opposite direction. The O-ring (45) must be placed between the impact sleeve (46) and the cylinder (1) and a pin (60) must be present between the cylinder (1) and the bottom distribution cover (42).

Nuts (34) should be tightened step by step on both sides.

After the assembly, check if the pawl mechanism is working correctly by rotating the drill bushing (49).

Run in the assembled rock drill for a short time using lower air pressure and increased lubrication.

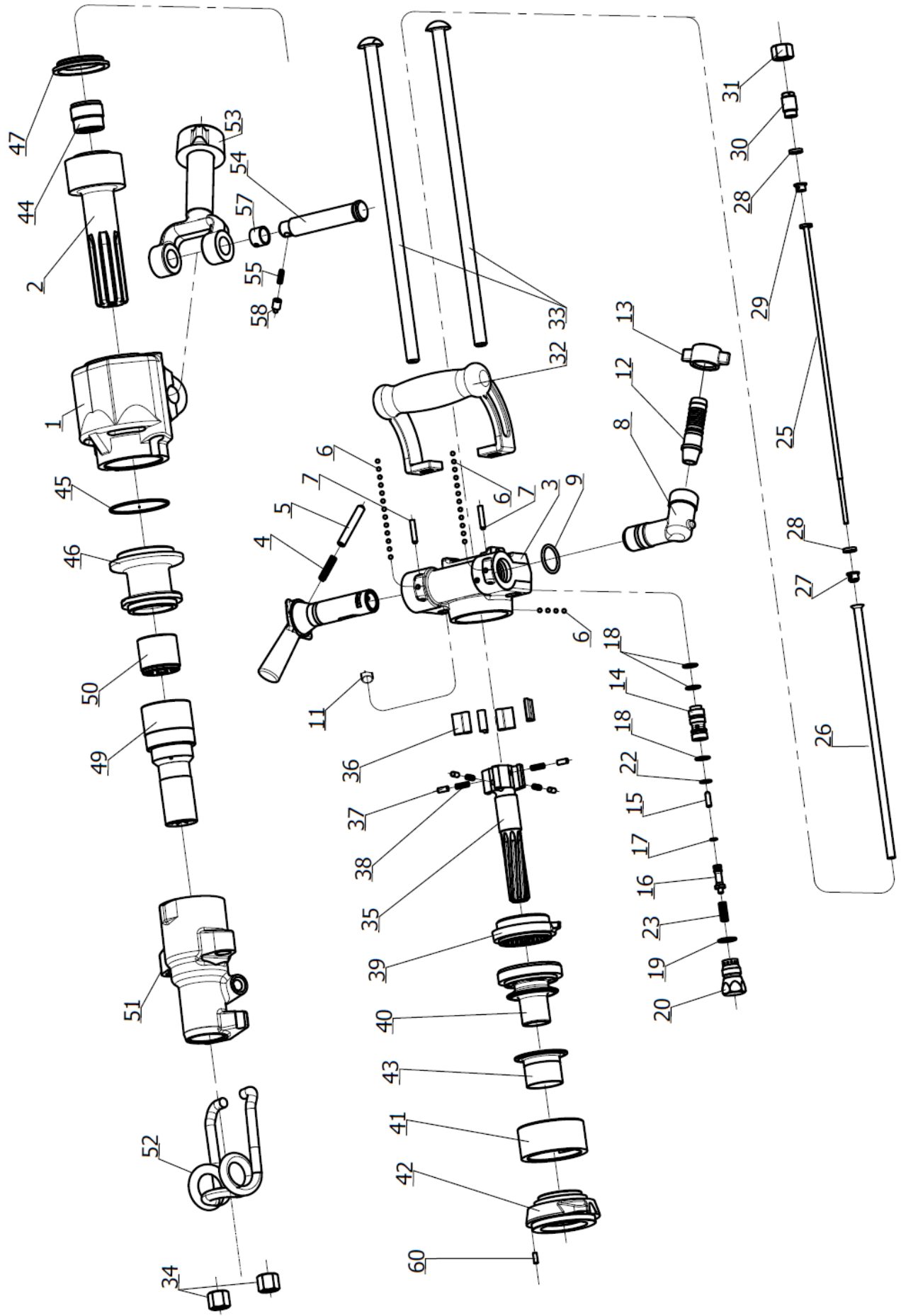

Parts List

REF.	PART NO.	PART NAME	QTY.	REQ.	NOTES
	9403-470	SET VK23			
1	5091-436	CYLINDER	1	J	
2	5002-313	PISTON	1	J	
3	5253-991	CYLINDER HEAD	1	J	
4	4500-731	SPRING	1	J	
5	3071-040	ARRESTING PIN	1	J	
6	324393	BALL 3/16"	41	J	
7	321020	PIN 6x31 3040-690	2	J	
8	4424-391	SUPPLY ELBOW R1	1	J	
8	4424-100	SUPPLY ELBOW Rd	1	N	
9	273034	RING O 40x32	1	J	
11	9421-060	DIRECT VALVE Js13	1	J	
12	319-265	SOCKET ST 25B/2 27,5	1	J	
12	4023-240	SOCKET Js 25	1	N	
13	319266	CAP NUT UM 10/2	1	J	
13	0871-222	CAP NUT Rd40	1	N	
14	0501-080	INNER PIECE	1	J	
15	3040-910	STARTING PIN	1	J	
16	3011-141	STARTING ROD	1	J	
17	273019	RING O 10x6	1	J	
18	273025	RING O 20x16	3	J	
19	273090	RING O 25x21	1	J	
20	0010-150	PLUG	1	J	
22	273023	RING O 16x12	1	J	
23	4500-721	SPRING	1	J	
25	8019-060	FLUSHING PIPE	1	J	
26	4307-070	AIR FLUSHING PIPE	1	J	
27	4070-020	INNER PIECE	1	J	
28	273173	SEALING 4201-940	2	J	
29	4070-030	INNER PIECE	1	J	
30	4072-020	PLUG	1	J	
31	0682-030	NUT	1	J	
32	1327-072	HANDLE	1	J	
33	0562-850	TIGHTENING SCREW	2	J	
34	311423	NUT M18x1.5	2	J	
35	5151-350	SCREW DRIVING LUG	1	J	
36	3792-090	PAWL	4	J	
37	3043-170	PIN	4	J	
38	315264	SPRING 4503-101	4	J	
39	3782-111	RATCHET	1	J	
40	3925-124	DISTRIBUTION COVER	1	J	
41	3924-133	DISTRIBUTION BODY	1	J	

42		3925-102	DISTRIBUTION COVER	1	J	
43		3902-091	DISTRIBUTION RING	1	J	
44		2068-320	TANG NUT	1	J	
45		273036	RING O 70x3	1	J	
46		2261-501	IMPACT SLEEVE	1	J	
47		4207-060	STOP	1	J	
49		2089-931	DRILL BUSHING 22x108	1	J	
50		0441-040	CARRIER	1	J	
51		5152-021	CYLINDER COVER	1	J	
52		4760-100	SPRING 22x108	1	J	
53		8011-062	STIRRUP	1	J	
54		3140-101	PIN	1	J	
55		4501-330	SPRING	1	J	
57		2045-170	RING	1	J	
58		3050-080	PIN	1	J	
60		311198	PIN 3X12	1	J	
		414290	QUICK COUPLING	1	N	

*J = Standard; N = Available on demand