



Design, manufacture, sales & service
of pneumatic tools

PERMON s.r.o.
Roztoky
27023 Křivoklát
CZECH REPUBLIC

tel: +420 (0)313 558145
+420 (0)313 558271-4
fax: +420 (0)313 558313
email: export@permon.cz
www.permon.cz

SEIT 1826 - SINCE 1826

OPERATION AND MAINTENANCE MANUAL

SKA 10B, SKA 10D, SKA 10DZ, SKA 12B, SKA 12D and SKA 12DZ

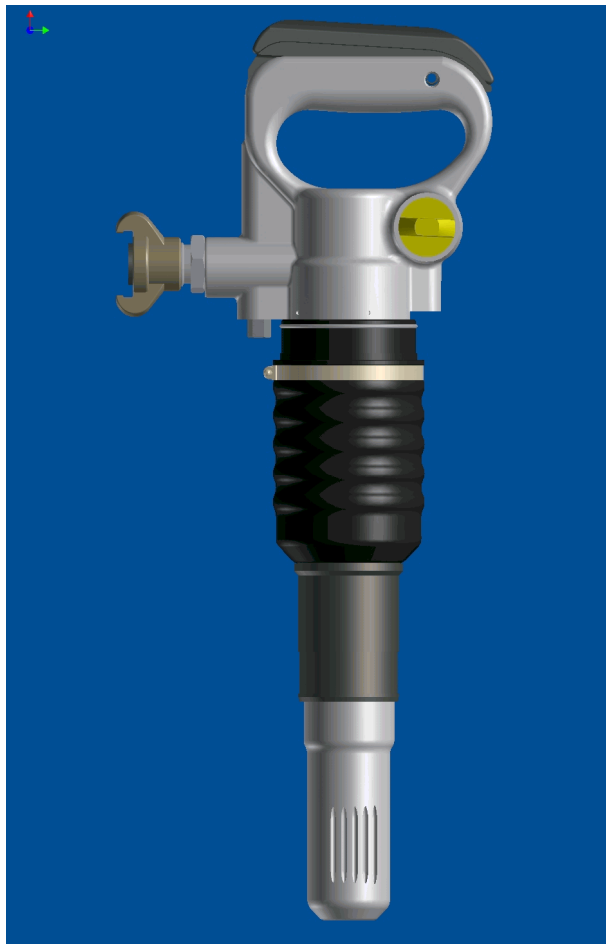

IMPORTANT SAFETY INFORMATION ENCLOSED. READ THIS MANUAL BEFORE OPERATING TOOL.

IT IS THE RESPONSIBILITY OF THE EMPLOYER TO PLACE THE INFORMATION IN THIS MANUAL INTO THE HANDS OF THE OPERATOR.

FAILURE TO OBSERVE THE FOLLOWING WARNINGS COULD RESULT IN INJURY.

SKA 10B, SKA 10D, SKA 10DZ, SKA 12B, SKA 12D and SKA 12DZ Pick Hammers are designed for the disintegration of low to medium strength materials (e.g. concrete, masonry bituminous asphalt etc).

Permon is not responsible for customer modifications of tools for applications on which Permon was not consulted.

PLACING TOOL IN SERVICE

- Always operate, inspect and maintain this tool in accordance with all regulations (local, state, federal and country), that may apply to hand held/hand operated pneumatic tools.
- For safety, top performance, and maximum durability of parts, operate this tool at 7.0 bar/700 kPa maximum air pressure at the inlet with 3/4" (19 mm) inside diameter air supply hose.
- Always turn off the air supply and disconnect the air supply hose before installing, removing or adjusting any accessory on this tool, or before performing any maintenance on this tool.
- Do not use damaged, frayed or deteriorated air hoses and fittings.
- Be sure all hoses and fittings are the correct size and are tightly secured.
- Always use clean, dry lubricated air at 7.0 bar/700 kPa maximum air pressure. Dust, corrosive fumes and/or excessive moisture can ruin the motor of an air tool.
- Do not lubricate tools with flammable or volatile liquids such as kerosene, diesel or jet fuel.
- Do not remove any labels. Replace any damaged label.

USING THE TOOL

- Always wear eye protection when operating or performing maintenance on this tool.
- Always wear hearing protection when operating this tool.
- Keep hands, loose clothing and long hair away from rotating end of tool.
- Anticipate and be alert for sudden changes in motion during start up and operation of any power tool.
- Keep body stance balanced and firm. Do not overreach when operating this tool.
- Tool accessories may continue to impact briefly after throttle is released.
- Air powered tools can vibrate in use. Vibration, repetitive motions or uncomfortable positions may be harmful to your hands and arms. Stop using any tool if discomfort, tingling feeling or pain occurs. Seek medical advice before resuming use.
- Use accessories recommended by Permon.
- This tool is not designed for working in explosive atmospheres.
- This tool is not insulated against electric shock.

The use of other than genuine Permon replacement parts may result in safety hazards, decreased tool performance, and increased maintenance, and may invalidate all warranties.

Repairs should be made only by authorised trained personnel. Consult your nearest Permon authorised service center.

WARNINGS

- Always wear eye protection when operating or performing maintenance on this tool.
- Always wear hearing protection when operating this tool.
- Always turn off the air supply and disconnect the air supply hose before installing, removing or adjusting any accessory on this tool, or before performing any maintenance on this tool.
- Do not use damaged, frayed or deteriorated air hoses and fittings.
- Air powered tools can vibrate in use. Vibration, repetitive motions or uncomfortable positions may be harmful to your hands and arms. Stop using any tool if discomfort, tingling feeling or pain occurs. Seek medical advice before resuming use.
- Do not carry the tool by the hose.
- Keep body stance balanced and firm. Do not overreach when operating this tool.
- Operate at 7.0 bar/700 kPa maximum air pressure)
- When wearing gloves and operating models with inside trigger, always be sure that the gloves will not prevent the trigger from being released.
- Wear safety shoes, hard hat, safety goggles, gloves, dustmask and any other appropriate protective clothing while operating the tool.
- Do not indulge in horseplay. Distraction can cause accidents.

- Keep hands and fingers away from the throttle lever until it is time to operate the tool.
- Never rest the tool or chisel on your foot.
- Never point the tool at anyone.
- Compressed air is dangerous. Never point an air hose at yourself or co-workers.
- Never blow clothes free of dust with compressed air.
- Be sure all hose connections are tight. A loose hose not only leaks but can come completely off the tool and while whipping under pressure, can injure the operator and others in the area. Attach safety cables to all hoses to prevent injury in case a hose is accidentally broken.
- Never disconnect a pressurised air hose. Always turn off the air supply and bleed the tool before disconnecting a hose.
- The operator must keep limbs and body clear of the chisel. If a chisel breaks, the tool with the broken chisel projecting from the tool will suddenly surge forward.
- Do not ride the tool with one leg over the handle. Injury can result if the chisel breaks while riding the tool.
- Know what is underneath the material being worked. Be alert for hidden water, gas, sewer, telephone or electric lines.
- Use only proper cleaning solvents to clean parts. Use only cleaning solvents, which meet current safety and health standards. Use cleaning solvents in a well-ventilated area.
- Do not flush the tool or clean any parts with diesel fuel. Diesel fuel residue will ignite in the tool when the tool is operated, causing damage to internal parts. When using models with outside triggers or throttle levers, take care when setting the tool down to prevent accidental operation.
- Do not operate the tool with broken or damaged parts.
- Never start the tool when it is lying on the ground.
- This tool is not designed for working in explosive atmospheres.
- This tool is not insulated against electric shock.

OPERATION

Lubrication

This tools are fitted with built-in oilers to ensure proper lubrication. Refill the oil reservoir beginning of each shift and every 4 hours working with the tool.

- Switch off the air outlet of the compressor. Disconnect the hammer from the air hose.
- Slowly (in the oiler reservoir can be a certain residual pressure) crew out oil fill plug (44) and pour oil into the reservoir (about 25 mm under reservoir top margin).
- Check sealing O-ring (43) and replace it if damaged. Screw in the oil fill plug (44) and tighten it properly.

Recommended environmentally friendly oils:

SETUZA PRIMOL EKO PNEU

BP BIOHYD SE46

ÖMV BIOHYD M 32

TOTAL HYDROBIO 46

Before storing the tool or if the tool is to be idle for a period exceeding twenty-four hours, pour about 3 cc of mineral oil into the air inlet and operate the tool for 5 seconds to coat the internal parts with oil.

Air Supply and Connections

Always use clean, dry air. Dust, corrosive fumes and/or excessive moisture can ruin the motor of an air tool. An air line filter can greatly increase the life of an air tool. The filter removes dust and moisture.

Make sure all hoses and fittings are the correct size and are tightly secured.

The tool is shipped from the factory with 3/4" G male inlet thread.

Accessory Installation

Always turn off the air supply and disconnect the air supply hose before installing, removing or adjusting any accessory on this tool or before performing any maintenance on this tool. Failure to do so could result in injury.

For Screwed retainer:

1. Screw out the retainer.
2. Check the rubber ring in the retainer and replace it if worn. Missing or worn ring could result in retainer breakage.
3. Insert chisel into the hammer.
4. Screw on firmly the retainer.

For Latch Type Retainer:

1. Operate the Latch until it is approximately 90 degrees to the body of the tool and clicks into position.
2. Insert the accessory into the tool until the collar of the accessory is past the Latch.
3. Operate the Latch until it is parallel to the tool and it clicks into position.

15 kg is the recommended amount of downforce to apply to the tool when working. The amount of downforce is correct when the tool hits rhythmically, is comfortable to hold and works efficiently.

- Do not repair the tool at the work site. Always take the tool to a repair shop. Never drag the tool on the ground. The air port and other openings will become clogged with dirt and debris.
- Compressed air is dangerous. When blowing the line clear of dirt, wear eye protection and keep the air line directed toward a safe, clear area.
- Always blow out the air line before using to clear the line of dirt.
- Do not operate the tool unless the chisel is against the work since this will cause premature wear of parts and reduce the vibration isolation properties of the tool.
- Always break material to the point of "give." Cracking does not result in a complete break. Clear away rubble as it is broken since uncleared rubble blocks the point of "give."
- Always take the right size "bite" with the tool. When working new material, experiment to find the right size "bite" required for breaking that material efficiently.
- If "bites" are too big, the operator will try to pry with the tool. This could break the chisel.
- The tool is designed for demolition, not prying. Always use a pick for prying. If "bites" are too small, the operator will be working too slowly.
- If the chisel or accessory should become stuck, do not use excessive force or mechanical means on the tool to pull out the chisel. Doing so will damage the vibration isolation unit. Break out the stuck chisel with a spare chisel or tool.

DISASSEMBLING THE SKA 10 AND SKA 12 PICKHAMMERS

GENERAL INSTRUCTIONS

- Clean the Pickhammer outer surface.
- Do not disassemble the pickhammer any further than necessary to replace or repair damaged or worn parts.
- Whenever grasping a pickhammer or a part in a vice, always use leather or copper-covered vice jaws to protect the surface of the part and help prevent distortion. Take extra care with threaded parts and housings.
- Do not remove any part that is a press fit in or on a subassembly unless the removal of the part is necessary for repairs or replacement.
- Do not disassemble the pickhammer unless a complete set of O-rings is available for replacement.

DISASSEMBLY OF THE FRONTHEAD

Screw retainer models

Unscrew retainer (12) off the cylinder (1) and remove chisel buffer (13) from inside retainer. Remove seal ring (8) from its groove in the cylinder.

Latch retainer models

Remove nut (17) and fronthead pinch bolt (16) from the fronthead (15). Lightly tap the fronthead (using a hide mallet if necessary) off the cylinder (1). Press or drift out the two fronthead spring pins (18, 19) and remove the latch lever (20). The plunger (22) and plunger spring (21) can be removed from the fronthead.

MAIN DISASSEMBLY

Grip handle body (24) firmly in a vice (use leather or copper covered vice jaws).

Insert three or four pieces of thin sheet steel approximately 8mm wide up into the muffler and beneath the retaining lip of the muffler moulding (9) from the handle end of the cylinder. This will allow the rubber retaining lip of the muffler to slide along past the groove in the cylinder nut (11) and make removal of the muffler easier. Note that the bearing sleeve and muffler are removed together. Slide muffler (9) and bearing sleeve (10) off over the cylinder assembly (1).

Use a small screwdriver to disengage the end of the locking ring (40) from the hole in the cylinder nut (11). Rotate the locking ring in its groove a little to prevent re-locking. (Removal of the locking ring is not necessary unless replacement is required.)

Use a large spanner (75 mm) across the flats of the cylinder nut (11) and unscrew the nut from the cylinder assembly. Remove the anti-rotation key (7) from its slot in the handle body (24). The key is provided with an M5 tapped hole to aid removal by a jacking screw if necessary.

The cylinder assembly (1) may now be slid from the handle assembly (23), take care to prevent loss of the cylinder spring (6) and o-ring (38).

HANDLE DISASSEMBLY

Grip handle body (24) in a vice (use leather or copper covered vice jaws).

Unscrew throttle valve plug (29) using a 13 mm spanner.

Withdraw throttle valve spring (28), throttle valve ball (27) and throttle valve plunger (26).

Remove the throttle lever (25) by pressing or drifting out spring pin (26).

Unscrew quick release coupling (31) from inlet bushing (30).

The inlet bushing (30) can be removed if required though it is assembled into the handle using a high strength retainer and disassembly is not normally necessary.

Unscrew plug (44).

Unscrew screw (45) and remove wick body (46) and wick (47) only if replacement needed.

CYLINDER DISASSEMBLY

Note: The cylinder assembly should not be disassembled unless there is evidence of excessive wear of the piston striking face, or evidence of excessive wear of the cylinder (1) bore, cushion bore or piston (3) diameters. Physical inspection of the above parts will require a new cylinder plug (6) and all O-rings to be available for re-assembly.

Tests to estimate wear in cylinder assembly components.

First thoroughly clean and degrease the whole cylinder assembly inside and out and blow dry. – **Caution: wear suitable personal protection, barrier cream, gloves and eye protection. Read any instructions and warnings specific to the degreasing agent.**

- *Piston striking face.*

If an indent caused by chisel contact, of approximately 0.5mm deep can be felt in the piston striking face – replace the piston.

- *Cushion wear.* (Test dry without oil) Hold the cylinder so the piston slides fully towards the valve end. Quickly invert and bring the cylinder vertical allowing the piston to fall towards the retainer end. If a metal to metal noise can be heard at the end of the piston stroke an air cushion is not present and a new cylinder assembly (1) and /or piston (3) may be required.

Note: Continued use of the hammer with insufficient cushion will result in premature cylinder failure.

- *Cylinder bore or piston diameter wear.*

Wear affecting these parts may have occurred if low hitting power is reported.

First ensure all airways into, and out from exhaust ports including muffler of tool are clear. Disassembly and precise measurement of the diameters will be required to confirm wear.

Disassembly

Grip the cylinder (1) horizontally in a vice (use leather or copper covered vice jaws).

Insert a mild steel bar of approx 20mm diameter by 300mm long into the nozzle end of the cylinder and press out or using a mallet drive out the cylinder plug (5) with the piston (3).

Note: The cylinder plug (6) is non metallic and is retained by a lip which will be destroyed when removed in this manner.

Caution:

Wear suitable eye protection, and be aware that the piston may be ejected or fall and cause injury.

The valve ring (4) may be removed by gently opening at the split and sliding the ring over the end of the cylinder.

Note: Take care not to stretch the ring.

Remove O-rings (38 may stick in handle body), (37), (36), and (39).

The nozzle (2) is pressed into the cylinder and retained with Loctite 601 – do not disassemble unless replacement is necessary.

The cylinder plugs (35) should not be removed, however check that they are present.

Inspect valve spring pins (33) and (34) for signs of wear and security.

ASSEMBLY OF THE SKA 10 AND SKA 12 PICKHAMMERS

GENERAL INSTRUCTIONS

- Before assembly of the breaker, clean all parts thoroughly and lubricate surfaces with a thin film of recommended oil – (see lubrication).
- Apply a thin film of O-ring lubricant to all O-rings before final assembly.
- It is recommended that the assembly of the nozzle (2) be carried out by the manufacturer or authorised distributor.
- The existence of a piston air cushion should be determined. Hold the cylinder vertically and allow the piston to drop down the bore small diameter first. An air cushion is present if the piston “bounces”, at the bottom of the cylinder and no metal to metal contact noise can be heard. If a cushion is not present contact your authorised Permon repair centre for advice.

CYLINDER ASSEMBLY

Grip the cylinder (1) vertically nozzle down, in a vice protected with leather or copper covered vice jaws.

If the cylinder has been disassembled completely rebuild in the following order.

Lubricate and insert the piston (3) small end first into the bore.

Locate the pilot diameter of cylinder plug (5) in cylinder bore and gently tap home using a hide mallet.

Gently spread apart the ends and slide valve ring (4) onto the cylinder. Locate the split around the valve spring pins (33) and (34).

Lubricate and replace the O-rings (37) & (36) in their grooves.

HANDLE ASSEMBLY

Position throttle lever (25) in its slot in the handle casting and align the holes in each part.

Drift or press home the spring pin (26). Check the throttle lever is free to move easily.

Grip the handle casting (24) in a vice protected with leather or copper covered vice jaws.

Lubricate and insert throttle valve plunger (26) into position reduced diameter out of the hole.

Replace the throttle valve ball (27) and spring (28) and retain in place with throttle valve plug (29), apply loctite 243 to the threads of the plug and screw home fully.

If the air inlet (30) has been removed, refit it into the handle casting using Loctite 243 and screw home fully.

Replace the quick release coupling (31).

Insert wick (47) into the wick body (46). Press the wick body (46) into the handle. Screw in screw (45).

Fill oil reservoir with recommended oil (see *Lubrication*). Put new O-ring (43) on the plug (44). Screw in the plug (44) and tighten it firmly.

MAIN ASSEMBLY

Firmly grip the handle assembly (23) vertically in a vice (protected with leather or copper covered vice jaws).

Position the O-ring (38) and stand the cylinder spring (6) centrally at the bottom of the handle bore.

Carefully slide the cylinder assembly (1) into the cylinder until the key slot in the handle body (24) aligns with the mating slot in the cylinder assembly (1). **Note:** Take care not to dislodge the cylinder spring off its face in the handle.

Lubricate the slot in the cylinder and replace the anti-rotation key.

Note: Check the handle is free to slide on the cylinder.

Remove the pickhammer from the vice.

Ensure that O-ring (39) is in place on the cylinder (nozzle end).

Lower the cylinder nut (11) onto the handle and cylinder assembly, engage the handle threads of the nut and tighten by hand. Fully tighten the Cylinder nut using a (75mm) spanner until the lock hole in cylinder nut (11) aligns with a hole in the handle body.

Note: Sight or feel for correct alignment with a suitably sized wire. Snap the locking ring pin in place. Slide the muffler (9) together with bearing sleeve (10) down the cylinder until the muffler retaining lip engages with the groove in the cylinder nut (11).

ASSEMBLY OF THE FRONTHEAD – SCREW RETAINER MODELS

Replace the sealing ring (8) in its groove in the cylinder.

Inspect the chisel buffer (13) for wear and replace if necessary, by sliding a new buffer into the retainer.

Note: Premature failure of the cylinder may occur if a worn chisel buffer (13) is not replaced. Permon recommend that the buffer (13) is checked frequently during use and replaced if necessary.

Screw the retainer onto the cylinder assembly.

ASSEMBLY OF THE FRONTHEAD – LATCH RETAINER MODELS

Grease the latch plunger (22) and plunger spring (21) and insert them into position in the fronthead (15).

Locate the latch lever (20) with the holes in the fronthead and press or drift into place the fronthead spring pins (18,19).

Check the operation of the latch.

Slide the fronthead (15) onto the end of the cylinder and align the bolt hole with the groove machined in the cylinder.

Fit fronthead pinch bolt (16) and secure with nut (17) tighten to 90 Nm torque.

ASSEMBLY CHECKS

Following service or repair the pickhammer should be checked for correct operation before being sent back to the job site.

Fit the correct size accessory into the pickhammer and connect to an airline. Using low pressure 2 bar (30psi) check to ensure the pickhammer is free of air leaks around the inlet connection and also that the pickhammer does not automatically start to operate without the trigger being depressed.

Increase the air pressure to 7 bar/700 kPa and run the tool in short bursts to check the tools starts and stops cleanly and without hesitation.

Pickhammer operating frequency should be as given in the specification table at the end of this manual.

SPECIFICATIONS

		SKA 10B	SK 10D	SK 10DZ
Weight	kg	10	10	11
Length	mm	490	490	490
Width	mm	210	210	210
Max. Working Pressure	bar	4-7	4-7	4-7
Air Consumption	m ³ /min	0,9	0,9	0,9
Impact Rate	1/min	2040	2040	2040
Chuck Size	mm	φ25x75	22 hex. x 82	22 hex. x 82
Vibration Level	m/s ²	5,1 m/s ²	5,1 m/s ²	5,1 m/s ²
Guarranteed Noise Level	L _{WA}	101	101	101

		SKA 12B	SKA 12D	SKA 12DZ
Weight	kg	12	12	13
Length	mm	650	650	650
Width	mm	210	210	210
Max. Working Pressure	bar	4-7	4-7	4-7
Air Consumption	m ³ /min	1,0	1,0	1,0
Impact Rate	1/min	1260	1260	1260
Chuck Size	mm	φ25x75	22 hex. x 82	22 hex. x 82
Vibration Level	m/s ²	3,8 m/s ²	3,8 m/s ²	3,8 m/s ²
Guarranteed Noise Level	L _{WA}	102	102	102

SPARE PARTS LIST

Ref.	Part No.						Part Name	Qty.
	9410461						Pickhammer SKA 10-B	
		9410470					Pickhammer SKA 10-D	
			9410480				Pickhammer SKA 10-DZ	
				9410520			Pickhammer SKA 12-B	
					9410530		Pickhammer SKA 12-D	
						9410540	Pickhammer SKA 12-DZ	
1	8323830			8323890			Cylinder Assy. R25x75	1
2	2001610			2001610			Nozzle R25x75	1
35	273413			273413				
1		8323840	8323850		8323900	8323910	Cylinder Assy. S22x82	1
2		2090751	2090751		2090751	2090751	Nozzle H22x82	1
35		273413	273413		273413	273413	Plug	2
3	5003671	5003671	5003671	5003690	5003690	5003690	Piston	1
4	3908130	3908130	3908130	3908130	3908130	3908130	Distribution Ring	1
5	722088	722088	722088	722089	722089	722089	Cover	1
6	315148	315148	315148	315144	315144	315144	Spring	1
7	1122290	1122290	1122290	1122290	1122290	1122290	Anti-rotation key	1
8	273330	273330		273330	273330		O-Ring 43x5,5	1
9	1730251	1730251	1730251	1730142	1730142	1730142	Muffler	1
10	2001591	2001591	2001620	2001630	2001630	2001591	Pipe	1
11	2010261	2010261	2010261	2010261	2010261	2010261	Nut	1
12	8042230	8042230		8042230	8042230		Retainer	1
13	273129	273129		273129	273129		Ring	1
14			8330041			8330041	Fronthead Assy.	1
15			5132230			5132230	Fronthead	1
16			309331			309331	Screw	1
17			311326			311326	Nut	1
18			311408			311408	Pin 12x50	1
19			311406			311406	Pin 20x50	1
20			5256102			5256102	Latch	1
21			315138			315138	Spring	1
22			0900950			0900950	Pin	1
23	8040241	8040241	8040241	8040241	8040241	8040241	Handle Assy.	1
24	5260010	5260010	5260010	5260010	5260010	5260010	Handle	1
25	1411172	1411172	1411172	1411172	1411172	1411172	Trigger	1
26	311038	311038	311038	311038	311038	311038	Spring Pin 8x28	1
27	722094	722094	722094	722094	722094	722094	Ball	1
28	315007	315007	315007	315007	315007	315007	Spring	1
29	0047080	0047080	0047080	0047080	0047080	0047080	Plug	1
30	4087330	4087330	4087330	4087330	4087330	4087330	Socket	1
31	414259	414259	414259	414259	414259	414259	Quick Coupling 3/4"	1
32	3081370	3081370	3081370	3081370	3081370	3081370	Starting Pin	1
43	273030	273030	273030	273030	273030	273030	Ring	1
44	0047090	0047090	0047090	0047090	0047090	0047090	Plug	1
45	309347	309347	309347	309347	309347	309347	Screw	1
46	722017	722017	722017	722017	722017	722017	Wick Body	1
47	722018	722018	722018	722018	722018	722018	Wick	1
33	311411	311411	311411	311411	311411	311411	Spring Pin 5x10	1
34	311417	311417	311417	311417	311417	311417	Spring Pin 3x19	1
36	273077	273077	273077	273077	273077	273077	O-Ring 60x2,5	1
37	273066	273066	273066	273066	273066	273066	O-Ring 57x2,5	1
38	273014	273014	273014	273014	273014	273014	O-Ring 63x53	1
39	273094	273094	273094	273094	273094	273094	O-Ring 66x56	1
40	4770450	4770450	4770450	4770450	4770450	4770450	Lock Ring	1
41	9950110	9950110	9950110	9950110	9950110	9950110	Latch Kit	0
42	548082	548082	548082	548082	548082	548082	Coupling	1

