



# ***Air line infrastructure***

## **Contents**

Introduction.....	280	Fittings.....	313
Product safety.....	281	Hoses.....	316
Air preparation units.....	282	Spiral hoses.....	321
Optimizer air tool oil.....	289	Productivity kits.....	322
Direct lubrication units.....	290	Pre-mounted hose kits.....	323
Quick couplings.....	292	Hose reels.....	324
Claw couplings.....	310	Blow guns.....	329
Ball valves.....	311	Test equipment.....	329
Swivel connectors.....	312		

# Ensure the full potential of your pneumatic tools

*To ensure that you benefit from the full potential power of your tools, Atlas Copco has developed a full range of air line infrastructure products to be used with pneumatic tools and equipment.*

### **PRODUCTIVITY**

By using Atlas Copco's air line infrastructure products and accessories you ensure that you have a correct air line installation for your tool. This will provide the correct air flow to the tool, ensuring that you benefit from its full potential power, and that you reach the correct torque in torque-controlled tools. By using the recommended installation you will also minimize the service requirements of the tool.

### **ENERGY EFFICIENCY**

With a correct installation you will not only achieve the tool's full potential power, you will also reduce energy costs. All Atlas Copco products and accessories are designed for minimum pressure drop, which ensures that the compressor is not "working overtime".

### **SAFETY**

All products and accessories are designed to meet the highest demands for a safe working environment. Atlas Copco has developed a wide range of safety couplings and hose reels to meet today's high standards in terms of workplace safety.

### **QUALITY**

All Atlas Copco products and accessories are made of the highest quality materials for long production cycles and to withstand rough treatment. Choose Atlas Copco and you will be sure of high quality products.



All local safety regulations with respect to installation, operation and overhaul must always be followed. Please read the separate instructions regarding safety which are supplied with all products in order to improve your own safety!

## BALL VALVE

- Switch off the compressed air with the ball valve when you are not working (see fig. 1).
- Open all ball valves gently in order to discover improperly tightened devices (see fig. 5).

## AIR PREPARATION UNITS

- Please check for solvents which change the structure of polycarbonate<sup>a</sup> bowls.

These solvents make the polycarbonate brittle so it can break. Normally polycarbonate is not easy to break. If you need to use aggressive solvents, please contact us and we will help you choose the right equipment.

- Use bowl guard.

An easy way to eliminate this type of accident is to use a bowl guard on MINI and MIDI units. The MAXI unit has an aluminum bowl with a new, more chemical resistant plastic on the inside as standard.

Check that the bowls are properly tightened and that all units are fitted together before switching on the compressed air with the ball valve.

## QUICK SAFETY COUPLINGS

To increase the safety and reduce the risk of operator injuries we recommend you to always buy couplings with a safety function. Couplings with a safety function are disconnected in

two stages in order to vent the coupling and minimize the risk of sudden component separation, which has the potential to cause operator injury.

Never open a quick coupling with a screwdriver in order to ventilate the air.

## CLAW COUPLINGS

- Be very careful (see fig. 1+2+3).

They are always open and must be used very carefully. To increase safety when using claw couplings, we recommend the claw LNH claw coupling with a lock nut.

## CLAMPS AND CONNECTIONS

- Avoid screwdrivers when tightening.

Check that they are properly tightened. Avoid screwdrivers when tightening, they can easily slip and damage your hand. Use a wrench. If you need to use a screwdriver, mount the clamp in a vice.

## HOSES

When mounting hoses on hose connections, use water and soap in order to make the hose slip on to the connection.

Do not use oil. Water and soap will dry up. Remove leaking hoses. A small leakage can quickly become a large hole.

## BLOW GUNS

- Use the safety version. It eliminates the risk of air at high pressure coming into direct contact with skin.

<sup>a</sup> Polycarbonate has good chemical resistance to all solvents except chemicals containing acetone, benzol, glycerine, some hydraulic and synthetic oils, chloroform, methyl alcohol, carbon tetrachloride (and similar solvents), carbon disulphide, perchloroethylene, toluene, trichloroethylene, xylene (nitrocellulose, thinner), acetic acid.

## FOLLOW THIS ORDER WHEN WORKING WITH CLAW COUPLINGS.

### How to open a claw coupling:

- 1 Close the ball valve.



- 2 Run the tool so the air ventilates out.



- 3 Release the claw coupling.



- 4 How to close a claw coupling:

Make sure that the two claw couplings are mounted together.

Use claw couplings with lock nut (LNH) or use a lock spring for safer locking.



- 5 Open the ball valve gently.



## Get maximum productivity from your tools

*Atlas Copco air preparation units are designed to help you get maximum productivity from your tools. They ensure minimal pressure drop and thus minimum energy losses in the air distribution system, benefiting the environment and cutting your operating costs. The lifetimes of your tools will be extended by using air preparation units and with that comes lower repair costs and less downtime. A correct air installation ensures productivity and good total economy.*

### **FILTER – FIL**

Water and dirt in your compressed air system will cause extensive corrosion damage and wear.

#### **Productivity**

Atlas Copco filters are equipped with a cyclone system. Using centrifugal force, this separates out a high percentage of the heavier solid water particles, while the filter ensures that the amount of dirt entering your tool is kept to a minimum. This means longer working cycles for the tools and minimum service time.

### **REGULATOR – REG**

Atlas Copco regulators ensure optimal flow at the specific flow rates required by Atlas Copco tools, or any other pneumatic tools.

#### **Energy efficiency**

By installing a regulator you will ensure that there will not be any unnecessary consumption of compressed air. The regulators reduce a variable primary pressure to a practically constant secondary pressure with a minimum of pressure drop.

#### **Productivity**

The regulator will optimize the performance of your tool, ensure torque accuracy and boost productivity.

### **LUBRICATOR – DIM**

Atlas Copco oil lubricators ensure a long, efficient and trouble-free life for your pneumatic tools and components.

#### **Productivity**

The use of a lubricator will increase the power in vane motors by about 10-15%.

#### **Energy efficiency**

With the use of a lubricator you will prolong the lifetime of a vane motor up to three times and the motor will work much more efficiently, and with less friction.



Filter – FIL



Regulator – REG



Lubricator – DIM

Air preparation unit MINI-K's main application is to prepare the air for pneumatic components. MINI-K units have a 1/4" BSP connection thread, a composite housing made of polyamide 66 and the bowls are made of polycarbonate.

**WORKING TEMPERATURE**

0°C to +50°C at 10 bar

**OPERATING PRESSURE**

Inlet pressure 0-10 bar

Outlet pressure 0.5-8 bar

**STANDARD FILTER**

30 µm

**PRESSURE GAUGE**

1/8" BSP



Model	Economical air flow l/s	Maximum air flow l/s	Bowl	Filter condensate drainage	Max condensate capacity cm <sup>3</sup>	Max oil capacity cm <sup>3</sup>	Weight kg	Ordering No.
<b>Filters</b>								
MINI FIL 08K-B	12	30	Polycarbonate	Manual	12	-	0.1	9092 0000 01
<b>Regulators</b>								
MINI REG 08K	10	20	-	-	-	-	0.11	9092 0000 61
<b>Lubricators</b>								
MINI DIM 08K	9	23	Polycarbonate	-	-	35	0.09	9092 0000 91
<b>Filter/regulator</b>								
MINI F/R 08K	12	17	Polycarbonate	Manual	12	-	0.12	9092 0001 21
<b>Filter/regulator+lubricator</b>								
MINI F/RD 08K	9	14	Polycarbonate	Manual	12	35	0.32	9092 0001 51

**NOTE:** Economical air flow: 8 bar inlet pressure, 6.3 bar outlet pressure, 0.2 bar pressure drop.

Maximum air flow: 10 bar inlet pressure, 6.3 bar outlet pressure, 1 bar pressure drop.

Not to be used with pulse tools.

All separate units, mounting brackets, assembly kits and pressure gauges need to be ordered separately. MINI-K F/RD unit is delivered complete with mounting bracket, assembly kit and pressure gauge.

Air preparation unit MINI-B's main application is to prepare the air for pneumatic components and tools with low air consumption. MINI-B has a 1/4" BSP connection thread and the housing is made of diecast zinc. The bowls are made of polycarbonate or the unit has metal bowls in zinc.



**WORKING TEMPERATURE**

0°C to +50°C at 10 bar

**OPERATING PRESSURE**

Inlet pressure 0-16 bar

Outlet pressure 0.5-8 bar

**STANDARD FILTER**

30 µm

**PRESSURE GAUGE**

1/8" BSP

Model	Economical air flow l/s	Maximum air flow l/s	Bowl	Filter condensate drainage	Max condensate capacity cm <sup>3</sup>	Max oil capacity cm <sup>3</sup>	Weight kg	Ordering No.
<b>Filters</b>								
MINI FIL 08B-B	12	24	Polycarbonate	Semi/automatic	22	-	0.25	9093 0032 11
MINI FIL 08B-C	12	24	Polycarbonate	Manual	22	-	0.25	9093 0032 41
MINI FIL 08B-D	13	24	Metal	Manual	22	-	0.25	9093 0032 71
<b>Regulators</b>								
MINI REG 08B	9	47.5	-	-	-	-	0.30	9093 0033 01
MINI REG 08P	8	47.5	-	-	-	-	0.30	9093 0000 31
<b>Lubricators</b>								
MINI DIM 08B	12	23	Polycarbonate	-	-	45	0.25	9093 0033 31
MINI DIM 08B-D	12	23	Metal	-	-	45	0.25	9093 0033 61
<b>Filter/regulator</b>								
MINI F/R 08B-B	9	38	Polycarbonate	Semi/automatic	22	-	0.35	9093 0033 91
MINI F/R 08B-C	9	38	Polycarbonate	Manual	22	-	0.35	9093 0034 21
<b>Filter/regulator+lubricator</b>								
MINI F/RD 08B-B	9	14.8	Polycarbonate	Semi/automatic	22	45	0.75	9093 0034 51
MINI F/RD 08B-C	9	14.8	Polycarbonate	Manual	22	45	0.75	9093 0034 81
<b>Filter+regulator+lubricator</b>								
MINI FRD 08B-B	9	13.8	Polycarbonate	Semi/automatic	22	45	0.95	9093 0062 11
MINI FRD 08B-C	9	13.8	Polycarbonate	Manual	22	45	0.95	9093 0062 41

**NOTE:** **Economical air flow:** 8 bar inlet pressure, 6.3 bar outlet pressure, 0.2 bar pressure drop.

**Maximum air flow:** 10 bar inlet pressure, 6.3 bar outlet pressure, 1 bar pressure drop.

Not to be used with pulse tools.

All separate units, mounting brackets, assembly kits and pressure gauges need to be ordered separately. The MINI F/RD and FRD units are delivered complete with mounting bracket, assembly kit and pressure gauge.

The MIDI Optimizer is suitable for more than 90% of the Atlas Copco tool range and is the best choice for assembly tools, percussive tools, drills, nibblers and grinders up to Turbo. The MIDI Optimizer has a 1/2" BSP connection thread and a housing and bowl of high-tech polymer. The bowl has a highly chemical resistant polypropylene insert and the bowl is directly screwed to the housing for easy handling.

### MIDI OPTIMIZER SELF-REGULATING NANO-LUBRICATOR

Adjusts automatically to the flow demand and ensures that the right amount of oil is supplied to the motor at all flow rates. This minimizes the lubrication needed. The nano oil mist, with a particle size of 200 nm, can be transported by the air stream up to 40 m. This means there is no oil in the hose and direct lubrication is not necessary. The lubricator can be refilled during operation. EP-versions are adjusted for use with impulse tools.



#### WORKING TEMPERATURE

-40°C to +60°C at 10 bar  
+2°C to +60°C at 10 bar for filters

**NOTE:** For dry compressed air, ice formation must be avoided.

#### OPERATING PRESSURE

Inlet pressure 0-16 bar  
Outlet pressure 0.5-8 bar  
Outlet pressure, HP versions 0.5-16 bar

#### STANDARD FILTER

30 µm

#### PRESSURE GAUGE

1/4" BSP  
Included in F/RD and FRD units

Model	Economical air flow l/s	Maximum air flow l/s	Bowl	Filter condensate drainage	Max condensate capacity cm <sup>3</sup>	Max oil capacity cm <sup>3</sup>	Weight kg	Ordering No.
<b>Filters</b>								
MIDI Optimizer FIL A	-	117	Polymer, plastic insert	Automatic	60	-	0.3	9093 0021 01
MIDI Optimizer FIL M/S	-	117	Polymer, plastic insert	Manual/semi auto	60	-	0.3	9093 0021 02
<b>Regulators</b>								
MIDI Optimizer REG	-	97	-	-	-	-	0.35	9093 0021 05
MIDI Optimizer REG LP	-	97	-	-	-	-	0.35	9093 0021 06
MIDI Optimizer REG HP	-	97	-	-	-	-	0.35	9093 0021 30
<b>Lubricators</b>								
MIDI Optimizer DIM	31	120	Polymer, plastic insert	-	-	90	0.3	9093 0021 10
MIDI Optimizer DIM EP	31	120	Polymer, plastic insert	-	-	90	0.3	9093 0021 33
<b>Filter/regulator</b>								
MIDI Optimizer F/R A	-	90	Polymer, plastic insert	Automatic	60	-	0.5	9093 0021 12
MIDI Optimizer F/R M/S	-	90	Polymer, plastic insert	Manual/semi auto	60	-	0.5	9093 0021 13
MIDI Optimizer F/R M/S HP	-	90	Polymer, plastic insert	Manual/semi auto	60	-	0.5	9093 0021 31
MIDI Optimizer F/R HP A	-	90	Polymer, plastic insert	Automatic	60	-	0.5	9093 0021 32
<b>Filter/regulator+lubricator</b>								
MIDI Optimizer F/RD A	31	55	Polymer, plastic insert	Automatic	60	90	1.0	9093 0021 16
MIDI Optimizer F/RD M/S	31	55	Polymer, plastic insert	Manual/semi auto	60	90	1.0	9093 0021 17
MIDI Optimizer F/RD A EP	31	55	Polymer, plastic insert	Automatic	60	90	1.0	9093 0021 35
MIDI Optimizer F/RD M/S EP	31	55	Polymer, plastic insert	Manual/semi auto	60	90	1.0	9093 0021 36
<b>Filter+regulator+lubricator</b>								
MIDI Optimizer FRD A	31	55	Polymer, plastic insert	Automatic	60	90	1.1	9093 0021 24
MIDI Optimizer FRD M/S	31	55	Polymer, plastic insert	Manual/semi auto	60	90	1.1	9093 0021 25

**NOTE:** **Economical air flow:** 8 bar inlet pressure, 6.3 bar outlet pressure, 0.2 bar pressure drop.  
**Maximum air flow:** 10 bar inlet pressure, 6.3 bar outlet pressure, 1 bar pressure drop.

All separate units, mounting brackets, assembly kits and pressure gauges need to be ordered separately. The MIDI Optimizer F/RD and FRD units are delivered complete with mounting bracket, assembly kit and pressure gauge.

EP For pulse tools, lubricator adjusted for impulsing tools  
A Automatic  
M/S Manual/semi automatic  
HP High pressure regulator  
LP Lockable regulator

The MIDI Optimizer is suitable for more than 90% of the Atlas Copco tool range and is the best choice for assembly tools, percussive tools, drills, nibblers and grinders up to Turbo. The MIDI Optimizer has a 3/4" BSP connection thread and a housing and bowl of high-tech polymer. The bowl has a highly chemical resistant polypropylene insert and the bowl is directly screwed to the housing for easy handling.

### MIDI OPTIMIZER SELF-REGULATING NANO-LUBRICATOR

Adjusts automatically to the flow demand and ensures that the right amount of oil is supplied to the motor at all flow rates. This minimizes the lubrication needed. The nano oil mist, with a particle size of 200 nm, can be transported by the air stream up to 40 m. This means there is no oil in the hose and direct lubrication is not necessary. The lubricator can be refilled during operation. EP-versions are adjusted for use with impulse tools.



#### WORKING TEMPERATURE

-40°C to +60°C at 10 bar  
+2°C to +60°C at 10 bar for filters

**NOTE:** For dry compressed air, ice formation must be avoided.

#### OPERATING PRESSURE

Inlet pressure 0-16 bar  
Outlet pressure 0.5-8 bar  
Outlet pressure, HP versions 0.5-16 bar

#### STANDARD FILTER

30 µm

#### PRESSURE GAUGE

1/4" BSP  
Included in F/RD and FRD units

Model	Economical air flow l/s	Maximum air flow l/s	Bowl	Filter condensate drainage	Max condensate capacity cm <sup>3</sup>	Max oil capacity cm <sup>3</sup>	Weight kg	Ordering No.
<b>Filters</b>								
MIDI Optimizer 3/4" FIL A	-	117	Polymer, plastic insert	Automatic	60	-	0.3	9093 0021 40
MIDI Optimizer 3/4" FIL M/S	-	117	Polymer, plastic insert	Manual/semi auto	60	-	0.3	9093 0021 41
<b>Regulators</b>								
MIDI Optimizer 3/4" REG	-	97	-	-	-	-	0.35	9093 0021 42
MIDI Optimizer 3/4" REG LP	-	97	-	-	-	-	0.35	9093 0021 43
MIDI Optimizer 3/4" REG HP	-	97	-	-	-	-	0.35	9093 0021 44
<b>Lubricators</b>								
MIDI Optimizer 3/4" DIM	31	120	Polymer, plastic insert	-	-	90	0.3	9093 0021 45
MIDI Optimizer 3/4" DIM EP	31	120	Polymer, plastic insert	-	-	90	0.3	9093 0021 54
<b>Filter/regulator</b>								
MIDI Optimizer 3/4" F/R A	-	90	Polymer, plastic insert	Automatic	60	-	0.5	9093 0021 46
MIDI Optimizer 3/4" F/R M/S	-	90	Polymer, plastic insert	Manual/semi auto	60	-	0.5	9093 0021 47
MIDI Optimizer 3/4" F/R M/S HP	-	90	Polymer, plastic insert	Manual/semi auto	60	-	0.5	9093 0021 48
MIDI Optimizer F/R 3/4" HP A	-	90	Polymer, plastic insert	Automatic	60	-	0.5	9093 0021 49
<b>Filter/regulator+lubricator</b>								
MIDI Optimizer 3/4" F/RD A	31	55	Polymer, plastic insert	Automatic	60	90	1.0	9093 0021 50
MIDI Optimizer 3/4" F/RD A EP	31	55	Polymer, plastic insert	Automatic	60	90	1.0	9093 0021 55
MIDI Optimizer 3/4" F/RD M/S	31	55	Polymer, plastic insert	Manual/semi auto	60	90	1.0	9093 0021 56
MIDI Optimizer 3/4" F/RD M/S EP	31	55	Polymer, plastic insert	Manual/semi auto	60	90	1.0	9093 0021 51

**NOTE:** Economical air flow: 8 bar inlet pressure, 6.3 bar outlet pressure, 0.2 bar pressure drop.

Maximum air flow: 10 bar inlet pressure, 6.3 bar outlet pressure, 1 bar pressure drop.

All separate units, mounting brackets, assembly kits and pressure gauges need to be ordered separately. The MIDI Optimizer F/RD and FRD units are delivered complete with mounting bracket, assembly kit and pressure gauge.

EP For pulse tools, lubricator adjusted for impulsing tools  
A Automatic  
M/S Manual/semi automatic  
HP High pressure regulator  
LP Lockable regulator



The high flow MAXI-B air preparation unit's main application is to prepare the air for pneumatic tools which are large air consumers when long distribution hoses and multi connectors are used. A good example is Atlas Copco Turbo grinders. The MAXI-B has a diecast zinc housing and aluminum bowls with polypropylene inserts and the bowl is directly screwed to the housing for easy handling.

### WORKING TEMPERATURE

-10°C to +50°C at 10 bar

**NOTE:** For dry compressed air, ice formation must be avoided.

### OPERATING PRESSURE

Inlet pressure 0-17.5 bar

Outlet pressure 0.5-12 bar

### STANDARD FILTER

30 µm

### PRESSURE GAUGE

1/4" BSP



Model	Economical air flow l/s	Maximum air flow l/s	Bowl	Filter condensate drainage	Max condensate capacity cm <sup>3</sup>	Max oil capacity cm <sup>3</sup>	Weight kg	Ordering No.
<b>Filters</b>								
MAXI FIL 25B-B	106	190 <sup>a</sup>	Metal	Semi/automatic	130	-	0.9	9093 0074 21
<b>Regulators</b>								
MAXI REG 25B	85	333	-	-	-	-	1.2	9093 0074 61
MAXI REG 25B-LP	85	333	-	-	-	-	1.2	9093 0074 81
<b>Lubricators</b>								
MAXI DIM 25B	87	295	Metal	-	-	500	0.8	9093 0075 21
<b>Filter/regulator</b>								
MAXI F/R 25B-B	84	316	Metal	Semi/automatic	130	-	1.5	9093 0075 51
<b>Filter/regulator+lubricator</b>								
MAXI F/RD 25B-B	82	244	Metal	Semi/automatic	130	500	2.8	9093 0075 81
MAXI FRD 25B-B	81	209	Metal	Semi/automatic	130	500	3.3	9093 0076 01

<sup>a</sup> 8 bar inlet pressure, 1 bar pressure drop.

**NOTE:** **Economical air flow:** 8 bar inlet pressure, 6.3 bar outlet pressure, 0.2 bar pressure drop.

**Maximum air flow:** 10 bar inlet pressure, 6.3 bar outlet pressure, 1 bar pressure drop.

All separate units, mounting brackets, assembly kits and pressure gauges need to be ordered separately. The MAXI F/RD and FRD units are delivered complete with mounting bracket, assembly kit and pressure gauge.

## Optional Accessories

### COMMON ACCESSORIES

Designation	Ordering No.			
	MINI-K	MINI-B	MIDI OPTIMIZER	MAXI-B
<b>Mounting bracket kit</b>	9090 1902 00	9092 0063 01	9093 0022 01	9093 0076 15
<b>Assembly kit</b>	9090 1901 90	9092 0062 71	9093 0022 02	9093 0076 31

Are included in combination units (FD, FTD, F/RD and FRD)  
Common accessories have to be ordered separately for separate units.

### FILTER (FIL) ACCESSORIES (30 µm filter element is included with all filters)

Designation	Ordering No.			
	MINI-K	MINI-B	MIDI OPTIMIZER	MAXI-B
<b>Filter element</b>				
30 µm	9090 1898 00	9092 0063 31	9093 0023 04	9093 0076 61
5 µm		9092 0063 61	9093 0023 05	9093 0076 71
<b>Bowl guard</b>		9092 0063 91		

### REGULATOR (REG) ACCESSORIES

Designation	Ordering No.			
	MINI-K	MINI-B	MIDI OPTIMIZER	MAXI-B
<b>Pressure gauge</b>				
0-10 bar				
Ø 40 mm	9090 1907 00	9090 1907 00		
Ø 50 mm		9090 1172 00	9090 2052 00	
Metal housing			9090 2052 01	
0-16 bar				
Ø 49 mm			9090 0239 00	9090 0239 00
Ø 50 mm		9090 1657 00		
<b>Panel mounting pressure gauge</b>				
0-10 bar				
Ø 50 mm		9090 1173 00	9090 1173 00	
<b>Key lock for regulator -LP</b>		9092 0074 11	9092 0074 11	9092 0074 11

Pressure gauge 0-10 bar is included in the combination units (F/RD and FRD)  
Pressure gauge has to be ordered separately for separate units.

### LUBRICATOR (DIM) ACCESSORIES

Designation	Ordering No.				
	MINI-K	MINI-B	MIDI Optimizer		MAXI-B
			MIDI 1/2"	MIDI 3/4"	
<b>Air distribution block kit</b>	9090 1900 90	9092 0064 51	9093 0022 03	9093 0022 04	9093 0076 41
<b>Bowl guard</b>		9092 0063 91			
<b>Glass sight dome</b>		9090 1121 00			

### FRL STAND

Designation	Ordering No.
FRL-Stand - suits all models	9090 2101 00
FRL-Stand kit	9090 3030 02
FRL-Stand MAXI BSP	9090 3030 04
FRL-Stand MIDI BSP	9090 3030 06

Mounting bracket kit

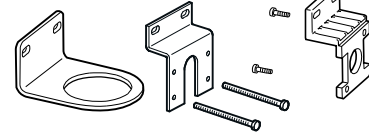

Assembly kit

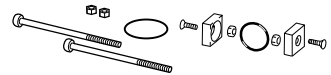

Filter element

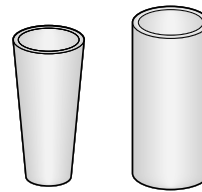

Bowl guard

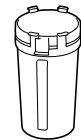

Pressure gauge

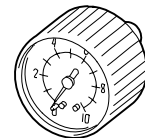

Panel mounting pressure gauge

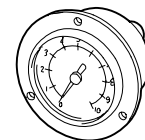

Key locks for regulator -LP

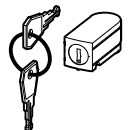

Air distribution block kit

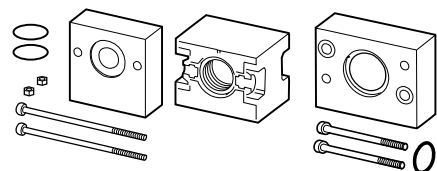

Glas sight dome



FRL stand



## OPTIMIZER AIR TOOL OIL

Atlas Copco Optimizer air tool oil is a white, oil based lubricant for pneumatic tools. It has excellent antiwear properties and contains additives preventing oxidation and foaming. Optimizer air tool oil provides a better working environment, compared to conventional mist lubrication oils and is recommended when stringent demands are placed on the working environment.

- Provides a better working environment.
- Excellent antiwear properties.
- Minimizes wear on components.



## Technical Data

Temperature range	-25°C to +70°C
Density at 15°C	869 kg/m <sup>3</sup>
Viscosity at 40°C	22 mm <sup>2</sup> /s
Pour point	-48°C
Flash point COC	>170°C

Model	Ordering No.
Optimizer 0.5 liter	9090 0000 02
Optimizer 1 liter	9090 0000 04
Optimizer 4 liter	9090 0000 06

## SINGLE POINT LUBRICATOR DOSOL

Accurate lubrication for tools in intermittent service.

The Atlas Copco DOSOL system for direct lubrication is based on an injector pump which meters out the oil in exact doses, actuated by pulses of compressed air. The oil dosage can be regulated from a fraction of a drop to a full drop.

- **Exact amount** – Precision injector, adjustable for exact amount of oil.
- **Oil directly at the tool** – The oil is conveyed through a capillary tube directly to the lubrication point.

A single-point lubricator (SPL) consists of an injector pump fitted to a valve body, converting interruptions in compressed air flow into pulses. In the majority of cases, an oil bowl is fitted on each lubricator.

Every DOSOL SPL unit can be finely tuned to inject from 1 to 1/10 of a drop of oil in 40 steps (30 to 3 mm<sup>3</sup>). Every DOSOL SPL unit includes as standard a counter with a switch that allows the lubricator to operate every first, fifth or tenth tool cycle.

The adjusting knob features a positive stop at both maximum and minimum settings, which means that a zero setting is not possible.

The preset quantity of oil is supplied to the tool through a small-bore nylon tube inside the air hose. 7.5 m of oil-filled nylon tubing is included as standard.



## MULTIPLE-POINT LUBRICATOR DOSOL

For supplying lubricant to an unlimited number of lubrication points on a machine or in a pneumatic system.

The DOSOL multiple-point lubricator (MPL) consists of a number of JECT 01 oil metering pumps assembled into a "package" with a common BASE base-plate. A stack may contain up to ten JECT 01 units. Several such assemblies may be used together.

- All oil pumps are supplied with oil via the BASE from an oil container or central oil reservoir. A line for pneumatic signals from the equipment to be lubricated is also connected to the BASE.
- The lubricant is conveyed through small-bore nylon tubing which should be ended with check valves.
- With the TEN counter the lubricator can be actuated every first, fifth or tenth tool cycle.

Every DOSOL MPL unit can be finely tuned to inject from 1 to 1/10 drop of oil in 40 steps (30 to 3 mm<sup>3</sup>). This helps to minimize the oil dose. The adjusting knob features a positive stop at both maximum and minimum settings, which means that zero setting is not possible.

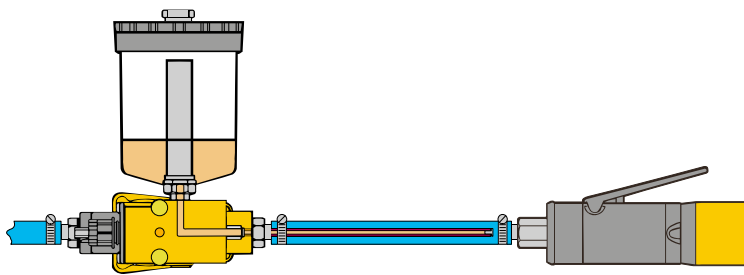

## SINGLE-POINT LUBRICATOR, DOS

Model	Connection thread BSP in	Air flow l/s		Working pressure bar		Temperature range °C		Ordering No.
		min	max <sup>a</sup>	min	max	min	max	
DOS 15B-C <sup>b</sup>	1/2	2.3	45	3.2	10	-30°	+60°	8202 4201 73
DOS 15B-CR <sup>c</sup>	1/2	2.3	45	3.2	10	-30°	+60°	8202 4202 72
DOS 20B-C <sup>b</sup>	3/4	2.3	53	3.2	10	-30°	+60°	8202 4201 81
DOS 20B-CR <sup>c</sup>	3/4	2.3	53	3.2	10	-30°	+60°	8202 4202 80

<sup>a</sup> At 6 bar and DP = 0.2 bar.

<sup>b</sup> With counter and 7.5 m oil-filled nylon tubing.

<sup>c</sup> With 0.3 l oil container counter and 7.5 m oil-filled nylon tubing.

## Optional Accessories

### FOR SINGLE POINT LUBRICATOR DOSOL

Designation	Ordering No.
Nylon tubing 3.2 mm outside diameter	
7.5 m, oil-filled	9090 1418 00
7.5 m, without oil	9090 1419 00
100 m, with oil	9090 1420 00
Barbed nipple for joining of 3.2 mm tubes	9090 1423 00
Check valve for outer end of nylon tubing, dia ext. 3.2 mm	9090 2050 00

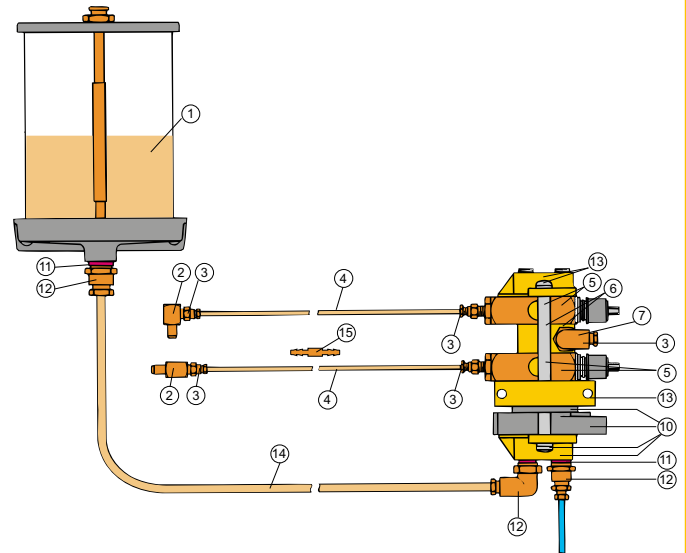

**NOTE:** When the counter TEN is used in MPL installations an intermediate, black plastic part is used (supplied with all TEN counters) between BASE and TEN.

### FOR MULTI POINT LUBRICATOR DOSOL

#### MULTIPLE-POINT LUBRICATOR, BASE, JECT 01

Designation		BSP in	Ordering No.
BASE baseplate	Plate		8202 4205 04
	Oil port	1/4	
	Air port	1/4	
	Clamp		
	Oil port	1/4	
	Air port	1/4	
JECT 01 oil pump	Oil delivery port	1/8	8202 4203 10

#### TEN-counter

When lubricating equipment with a very low air consumption or very short time in operation it may be difficult to set a sufficiently small dose of oil. In such cases a counter is connected underneath the base plate BASE. The oil pumps will then be actuated only on each, every fifth or every tenth air pulse. The air signal is connected to the clamp underneath the counter.

Ordering No. 8202 4206 03

#### Side-ported air block kit

If all pumps are not to be actuated simultaneously, a signal block is installed between the oil pumps in the stack. The pumps below the signal block will then be actuated via the base plate BASE and those above it from a separate signal via the signal block.

Ordering No. 8202 4206 03

Ref No. in figure	Designation	Ordering No.
1	Oil container 0.3 l for direct mounting 0.95 l for wall mounting (1/4" BSP female) 1.9 l for wall mounting (1/4" BSP female)	9090 1415 00 9090 1416 00 9090 1417 00
2	Check valve 1/8" BSPT 90° elbow male x 1/8" BSP female 1/8" BSPT, straight male x 1/8" BSP female	9090 1427 00 9090 1426 00
3	Male adapter 1/8" BSPT, straight for tube outer diameter 3.2 mm	9090 1425 00
4	Capillary tubing 7.5 m, outer dia. 3.2 mm prefilled with oil 7.5 m, outer dia. 3.2 mm without oil 100 m, outer dia. 3.2 mm with oil	9090 1418 00 9090 1419 00 9090 1420 00
5	JECT 01 kit <sup>a</sup>	8202 4203 10
6	Side-ported air block kit	9090 1424 00
7	Fiber packing for 1/8" BSP	0657 5742 00
10	Counter TEN kit	8202 4206 03
11	Fiber packing for 1/4" BSP	0657 5764 00
12	Male adapter 1/4" BSP, straight for tube outer diameter 8 mm	9090 0715 00
13	BASE kit	8202 4205 04
14	Nylon tube, outer diameter 8 mm (sold by the meter)	9030 0060 00
15	Barbed nipple for joining of nylon tubes outer diameter 3.2 mm	9090 1423 00
16	Nylon tube outer diameter 5 mm (sold by the meter)	9030 0059 00

<sup>a</sup> With high temperature Viton seals 8202 4203 15.

# Introduction – Quick Couplings

## Ensure the highest air flow and lowest pressure drop of your pneumatic tools

Whenever tools or pneumatic equipment need to be changed, or you need to make quick connections of hoses to an air outlet, Atlas Copco couplings are the energy efficient and high productivity choice.

### ENERGY EFFICIENCY

All Atlas Copco couplings are designed to ensure minimum pressure drop and thus reduce energy consumption.

### PRODUCTIVITY

Exceptionally high air flow ensures full power to your tools.

### QUALITY

Atlas Copco couplings are light and compact and the bodies are made of hardened steel, which provides long life in the toughest applications.

### ERGONOMICS

The couplings from Atlas Copco features compact dimensions and low weight for the operator.

### SAFETY

ErgoQIC and SmartQIC are vented safety versions to minimize the risk of sudden component separation and sound bang. The safety features are according to EN 983 and ISO 4414.

### THE RANGE

Atlas Copco offers four product groups of quick couplings in many international standards:

- ErgoQIC - full flow coupling.
- SmartQIC - Safety vented coupling.
- QIC - Entry level coupling.
- Claw - High flow and durable coupling.



## Selection Guide

Standard Type	Global standard			Euro standard			US standard / ISO 6150-B			Asia standard	
	08	10		7.6 (7.4) mm	10.4 mm	15 mm	5.3 mm (1/4")	8.2 mm (3/8")	11 mm (1/2")	7.5	
Atlas Copco ErgoQIC	08	10		10AC	08E	15E		08US	10US	15US	10 A
Atlas Copco SmartQIC					08E	15E		08US	10US	15US	10 A
Atlas Copco QIC				10				08			
Atlas Copco Claw			Claw								
CEJN					320	410		310	430	550	315
Oetiker					SC C			SC B1	SC E	SC H	SC D
Tema				1650	1600	1700	1750	1400			
Rectus				33	25/26	27	34	23/24	30	37	13
Prevost					ESC/ERC07			IRC/ISC06	IRC/ISC08	ISG 11	ORG
Nitto Kohki											20/30/40
Amflo								C20B	C26	C10	
Bosch					7.2						
Parker						55		30 / B23	25F	17	
Foster								3003	4404	5205	
Abnox					x						
Afnor NF 49053								x	x	x	
Camozzi					508/5180						
Dynaquip								1/4"	3/8"		
EWO					x						
Festo					KD						
Gromelle								600	900		
Hansen								22/3000	400/4000	500/5000	
Ingersoll Rand					7S7			A2/MS/102	A3/103/203	A4/104/204	
Kaeser					x						
Legris					25/26	27		23/24	30		13
Tomco								180	4000	5000	

## MAXIMIZE YOUR PRODUCTIVITY!

Select full flow couplings from Atlas Copco



- Recommended by Atlas Copco for your application and tool.

		Air flow requirements	ErgoQIC 08US	ErgoQIC 08 ErgoQIC 10AC	ErgoQIC 10 A	ErgoQIC 08E	ErgoQIC 10US	ErgoQIC 10	ErgoQIC 15E	ErgoQIC 15US
Screwdrivers	Bolt size	M2-M6	2-8 l/s	•	•	•	•			
	Bolt size	1/4" HEX and 3/8"	2-9 l/s	•	•	•	•			
Impact wrenches	Bolt size	3/8" and 1/2"	10-20 l/s		•	•	•	•		
	Bolt size	1" and 1 1/2"	28-37 l/s					•	•	•
	Bolt size	M4-M5	9 l/s	•	•	•	•			
Pulse tools	Bolt size	M6-M12	15-25 l/s	•	•	•	•	•	•	
	Bolt size	M14-M20	32-49 l/s					•	•	•
	Power	<820 W	8-21 l/s	•	•	•	•			
Drills	Size	<7 kg	6.5-14 l/s	•	•	•	•			
	Power	<500 W	3-10 l/s	•	•	•	•			
Chipping hammers	Power	500-900 W	7-19 l/s		•	•	•	•		
	Power	0.9-2 kW	20-35 l/s		•	•	•	•	•	•
	Power	<2.5 kW	32 l/s					•	•	•
Turbine grinders	Power	<2.5 kW	32 l/s					•	•	•
Blow guns		4-7.5 l/s	•	•	•	•				

### ERGOQIC

The ErgoQIC coupling is a ball valve coupling with a safety feature offering a higher flow than ordinary coupling systems. The ErgoQIC is a strong and durable full flow quick coupling with no air restriction inside the coupling. It is suitable for assembly tools, drills and grinders. Upgrading any air system with ErgoQIC will give the benefits of productivity and energy efficiency. ErgoQIC is designed to minimize the risk of sudden component separation and sound bang. The safety features are according to EN 983 and ISO 4414. It is made of hardened steel.

The ErgoQIC disconnects in two steps; first you push in and bend slowly – the pressurized air hose will then vent, and as a second step you can disconnect without risk of harming the operator.



### SMARTQIC

SMARTQIC is the latest generation of pneumatic safety couplings and nipples. The couplings offers high flow and low pressure drop with innovative safety features. The design has a unique safety venting feature when disconnecting, thus minimizing risk of injury to the operator.

Durable and tough, the couplings are made out of zinc-plated steel/brass material and the entire product range complies with safety standards ISO 4414 and EN 983. SMARTQIC couplings also complies with OSHA 1910.95.

Suitable for many types of applications and pneumatic tools; such as screwdrivers, assembly tools, drills and grinders.



### CLAW

CLAW couplings are made from drop-forged, hardened steel which can withstand rough treatment and ensures a long life even under difficult conditions. The coupling head is the same for all hose sizes, which can therefore be freely combined. The recommended maximum working pressure is 10 bar.



### MULTIFLEX SWIVEL

MultiFlex Swivel is a multi-directional connector. Once the tool is connected the hose will stay in the ideal position however much the operator and the tool move around. The MultiFlex bends and rotates 360° in all directions while the hose stays straight.





Nipple profile

## ErgoQIC 08

### ATLAS COPCO GLOBAL STANDARD

The ErgoQIC 08 is a full flow quick coupling with no air restriction inside the coupling. It is suitable for assembly tools, drills and small grinders. Upgrading any air system with ErgoQIC 08 will give the benefits of productivity and energy efficiency.

- Full flow coupling.
- Ergonomic design, small size and low weight.
- Strong and durable.
- Safety feature according to EN 983 / ISO 4414.
- Protective rubber cover available.
- Main market: Global.

### Technical Data

Max flow capacity	29 l/s (0.5 bar $\Delta P$ )
Economical air flow	18 l/s (0.2 bar $\Delta P$ )
Max working pressure	16 bar
Temperature range	-10°C to +70°C

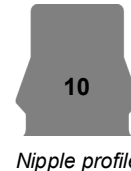

Nipple profile

## ErgoQIC 10

### ATLAS COPCO GLOBAL STANDARD

The ErgoQIC 10 is a full flow coupling with no air restriction inside the coupling. It is suitable for assembly tools, drills and grinders. Upgrading any air system with ErgoQIC 10 will give the benefits of productivity and energy efficiency.





- Extreme full flow coupling.
- Strong and durable.
- Minimized connection force.
- Safety feature according to EN 983 / ISO 4414.
- Protective rubber cover available.
- Main market: Global.

### Technical Data

Max flow capacity	60 l/s (0.5 bar $\Delta P$ )
Economical air flow	40 l/s (0.2 bar $\Delta P$ )
Max working pressure	16 bar
Temperature range	-10°C to +70°C



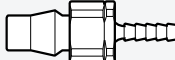
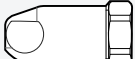

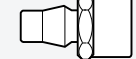

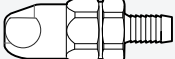

## ERGOQIC 08 AND ERGONIP 08, 18 L/S (recommended air flow at 6.3 bar pressure)

Connection type	Coupling ErgoQIC 08	Ordering No.	Size		Connection type	Nipple ErgoNIP 08	Ordering No.	Size	
			mm	in				mm	in
<b>H – Hose</b> 	H06	8202 1110 04	6.3	1/4	<b>H – Hose</b> 	H05	8202 1210 33	5	3/16
	H08	8202 1110 12	8	5/16		H06	8202 1210 37	6.3	1/4
	H10	8202 1110 38	10	3/8		H08	8202 1210 45	8	5/16
	H13	8202 1110 40	12.5	1/2		H10	8202 1210 52	10	3/8
<b>M – Male</b> 	M08	8202 1110 61	1/4 BSP	<b>SH – Safety Hose<sup>a</sup></b> 	SH06	8202 1210 39	6.3	1/4	
	M10	8202 1110 79	3/8 BSP		SH08	8202 1210 47	8	5/16	
	M15	8202 1110 87	1/2 BSP		SH10	8202 1210 50	10	3/8	
<b>F – Female</b> 	F08	8202 1110 90	1/4 BSP	<b>M – Male</b> 	M06	8202 1210 03	1/8 BSP		
	F10	8202 1110 95	3/8 BSP		M08	8202 1210 11	1/4 BSP		
<b>Protective cover</b> 	9090 1940 00				M10	8202 1210 29	3/8 BSP		
					M15	8202 1210 31	1/2 BSP		
					<b>F – Female</b> 	F08	8202 1210 60	1/4 BSP	
						F10	8202 1210 62	3/8 BSP	

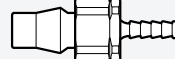
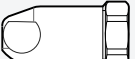
<sup>a</sup> For joining hoses longer than 3 meters.

## ERGOQIC 10 AND ERGONIP 10, 40 L/S (recommended air flow at 6.3 bar pressure)

Connection type	Coupling ErgoQIC 10	Ordering No.	Size		Connection type	Nipple ErgoNIP 10	Ordering No.	Size	
			mm	in				mm	in
<b>H – Hose</b> 	H06	8202 1120 30	6.3	1/4	<b>H – Hose</b> 	H06	8202 1220 35	6.3	1/4
	H08	8202 1120 40	8	5/16		H08	8202 1220 43	8	5/16
	H10	8202 1120 02	10	3/8		H10	8202 1220 50	10	3/8
	H13	8202 1120 10	12.5	1/2		H13	8202 1220 68	12.5	1/2
	H16	8202 1120 50	16	5/8		H16	8202 1220 76	16	5/8
	H20	8202 1120 60	19	3/4		H20	8202 1220 77	19	3/4
<b>M – Male</b> 	M08	8202 1120 85	1/4 BSP	<b>SH – Safety Hose<sup>a</sup></b> 	SH06	8202 1220 37	6.3	1/4	
	M10	8202 1120 93	3/8 BSP		SH08	8202 1220 45	8	5/16	
	M15	8202 1120 97	1/2 BSP		SH10	8202 1220 52	10	3/8	
	M20	8202 1120 98	3/4 BSP		SH13	8202 1220 70	12.5	1/2	
	M25	8202 1120 99	1 BSP		SH16	8202 1220 74	16	5/8	
<b>F – Female</b> 	F08	8202 1121 00	1/4 BSP	<b>M – Male</b> 	M08	8202 1220 01	1/4 BSP		
	F10	8202 1121 05	3/8 BSP		M10	8202 1220 19	3/8 BSP		
	F15	8202 1121 10	1/2 BSP		M15	8202 1220 27	1/2 BSP		
<b>Protective cover</b> 	9090 1931 00				<b>F – Female</b> 	F08	8202 1220 84	1/4 BSP	
						F10	8202 1220 86	3/8 BSP	
						F15	8202 1220 88	1/2 BSP	

<sup>a</sup> For joining hoses longer than 3 meters.

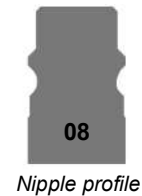
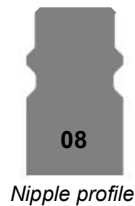

## ErgoQIC 08E

### EURO STANDARD 7.6 (7.4)

The ErgoQIC 08E is a full flow quick coupling with no air restriction inside the coupling. It is suitable for assembly tools, drills and small grinders. Upgrading any air system using Eurostandard nipples with ErgoQIC 08E couplings will give the benefits of productivity and energy efficiency.

- Full flow coupling.
- Ergonomic design, small size and low weight.
- Strong and durable.
- Safety feature according to EN 983 / ISO 4414.
- Protective rubber cover available.
- Main market: Europe.

## Technical Data

Max flow capacity	38 l/s (0.5 bar $\Delta P$ )
Economical air flow	24 l/s (0.2 bar $\Delta P$ )
Max working pressure	16 bar
Temperature range	-10°C to +70°C

## SmartQIC 08E

### EURO STANDARD 7.6 (7.4)

Safety coupling with venting connection, high flow and low pressure drop.



Common standard used in EU-markets for many types of assembly and material removal tools.

- High reliability with low pressure drop.
- Safety function with vented connection.
- High durability and easy handling.
- High air flow and increased productivity.
- Minimizes hose whip and injuries to operator.
- Long life time.
- Safety feature according to ISO-standard 4414 and EN 983.
- Complies with OSHA 1910.95.
- Main market: Europe.



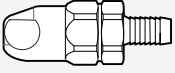

## Technical Data

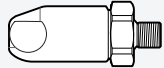
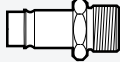
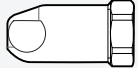
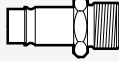
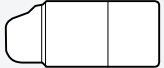
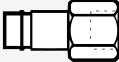
Max flow capacity	38 l/s (0.5 bar $\Delta P$ )
Economical air flow	35 l/s (0.2 bar $\Delta P$ )
Max working pressure	16 bar
Temperature range	-20°C to +100°C

## ERGOQIC 08E AND NIP EU 7.6, 24 L/S (recommended air flow at 6.3 bar pressure)

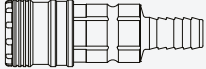
Connection type	Coupling ErgoQIC 08E		Size		Connection type	Nipple NIP EU 7.6		Size	
	Ordering No.		mm	in		Ordering No.		mm	in
<b>H – Hose</b> 	H06	8202 1106 00	6.3	1/4	<b>H – Hose</b> 	H05	8202 1204 00	5	3/16
	H08	8202 1106 01	8	5/16		H06	8202 1204 05	6.3	1/4
	H10	8202 1106 02	10	3/8		H08	8202 1204 10	8	5/16
	H13	8202 1106 03	12.5	1/2		H10	8202 1204 15	10	3/8
<b>M – Male thread</b> 	M08	8202 1106 04	1/4	BSP	<b>M – Male thread</b> 	M06	8202 1204 25	1/8	BSP
	M10	8202 1106 05	3/8	BSP		M08	8202 1204 30	1/4	BSP
	M15	8202 1106 06	1/2	BSP		M10	8202 1204 35	3/8	BSP
<b>F – Female</b> 	F08	8202 1106 07	1/4	BSP	<b>MT – Male taper thread</b> 	MT08	8202 1204 40	1/4	BSPT
	F10	8202 1106 08	3/8	BSP		MT10	8202 1204 45	3/8	BSPT
	F15	8202 1106 09	1/2	BSP		MT15	8202 1204 50	1/2	BSPT
<b>Protective cover</b> 		9090 1940 01			<b>F – Female</b> 	F08	8202 1204 55	1/4	BSP
						F10	8202 1204 60	3/8	BSP

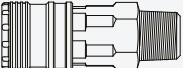
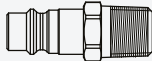
## SMARTQIC 08E AND NIP 08E, EU 7.6 35 L/S (recommended air flow at 6.3 bar pressure)

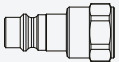
Connection type	Coupling SmartQIC-08E		Size		Connection type	Nipple NIP-08E		Size	
	Ordering No.		mm	in		Ordering No.		mm	in
<b>H – Hose</b> 	H08	4221 0010 00	8	5/16	<b>H – Hose</b> 	H06	4221 0011 00	6.3	1/4
	H10	4221 0010 01	10	3/8		H08	4221 0011 01	8	5/16
	H13	4221 0010 02	13	1/2		H10	4221 0011 02	10	3/8
<b>M – Male</b> 	M06	4221 0010 03	1/4	BSPT	<b>M – Male</b> 	M06	4221 0011 04	1/4	BSP
	M10	4221 0010 04	3/8	BSPT		M10	4221 0011 05	3/8	BSP
	M15	4221 0010 05	1/2	BSPT		M15	4221 0011 06	1/2	BSP
<b>F – Female</b> 	F06	4221 0010 06	1/4	BSP	<b>F – Female</b> 	F06	4221 0011 07	1/4	BSP
	F10	4221 0010 07	3/8	BSP		F10	4221 0011 08	3/8	BSP
	F15	4221 0010 08	1/2	BSP		F15	4221 0011 09	1/2	BSP

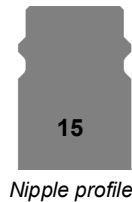

### ErgoQIC 15E

#### EURO STANDARD 10.4

The ErgoQIC 15E is a full flow coupling with no air restriction inside the coupling suitable for large air consuming assembly tools, drills and grinders. Upgrading any air system with ErgoQIC 15E will give the benefit of productivity and energy efficiency.

- Extreme full flow coupling.
- Strong and durable.
- Minimized connection force.
- Safety feature according to EN 983 / ISO 4414.
- Main market: Europe.

#### Technical Data

Max flow capacity	76 l/s (0.5 bar ΔP)
Economical air flow	49 l/s (0.2 bar ΔP)
Max working pressure	16 bar
Temperature range	-20°C to +80°C

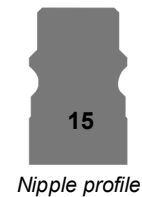

### SmartQIC 15E

#### EURO STANDARD 10.4

Safety coupling with venting connection, high flow and low pressure drop.

Common standard used in EU-markets for many types of assembly and material removal tools.

- High reliability with low pressure drop.
- Safety function with vented connection.
- High durability and easy handling.
- High air flow and increased productivity.
- Minimizes hose whip and injuries to operator.
- Long life time.
- Safety feature according to ISO-standard 4414 and EN 983.
- Complies with OSHA 1910.95.
- Main market: Europe.

#### Technical Data

Max flow capacity	68 l/s (0.5 bar ΔP)
Economical air flow	63 l/s (0.2 bar ΔP)
Max working pressure	16 bar
Temperature range	-20°C to +100°C

## Euro standard 15 mm

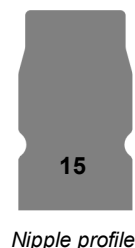

### QIC 15

#### EURO STANDARD 15 MM

The QIC 15 quick coupling is suitable for assembly tools, grinders and drills. The QIC 15 can withstand extremely rough handling in tough applications.

- Extremely high flow.
- Strong and durable.
- One-hand operation.
- Main market: Europe.



#### Technical Data

Max flow capacity	48 l/s (0.5 bar ΔP)
Economical air flow	30 l/s (0.2 bar ΔP)
Max working pressure	10 bar
Temperature range	-20°C to +80°C

# Quick Couplings

# Euro standard 10.4 and 15 mm

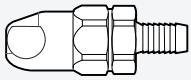
## ERGOQIC 15E AND NIP 15E, 49 L/S (recommended air flow at 6.3 bar pressure)

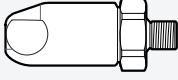
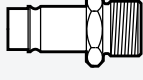
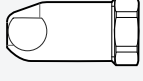
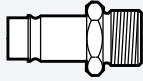
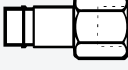

Connection type	Coupling ErgoQIC 15E	Ordering No.	Size		Connection type	Nipple NIP 15E	Ordering No.	Size	
			mm	in				mm	in
<b>H – Hose</b> 	H10	8202 1106 50	10	3/8	<b>H – Hose</b> 	H06	8202 1253 00	6.3	1/4
	H13	8202 1106 51	12.5	1/2		H08	8202 1253 05	8	5/16
	H16	8202 1106 52	16	5/8		H10	8202 1253 10	10	3/8
	H20	8202 1106 53	19	3/4		H13	8202 1253 15	12.5	1/2
<b>M – Male</b> 	M10	8202 1106 60	3/8	BSP	<b>M – Male</b> 	M10	8202 1253 25	3/8	BSP
	M15	8202 1106 61	1/2	BSP		M15	8202 1253 30	1/2	BSP
	M20	8202 1106 62	3/4	BSP		M20	8202 1253 34	3/4	BSP
	M25	8202 1106 63	1	BSP					
<b>F – Female</b> 	F10	8202 1106 70	3/8	BSP	<b>MT – Male taper thread</b> 	MT08	8202 1253 35	1/4	BSPT
	F15	8202 1106 71	1/2	BSP		MT10	8202 1253 40	3/8	BSPT
					<b>F – Female</b> 	F08	8202 1253 50	1/4	BSP
				F10		8202 1253 55	3/8	BSP	
				F15		8202 1253 60	1/2	BSP	
				F20		8202 1253 63	3/4	BSP	

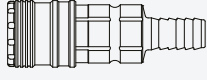
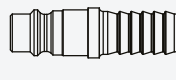
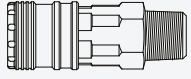
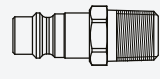
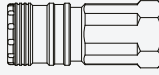
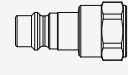
## SMARTQIC 15E AND NIP-15E, EU 10.4, 63 L/S (recommended air flow at 6.3 bar pressure)

Connection type	Coupling SmartQIC 15E	Ordering No.	Size		Connection type	Nipple NIP 15E	Ordering No.	Size	
			mm	in				mm	in
<b>H – Hose</b> 	H10	4221 0020 00	10	3/8	<b>H – Hose</b> 	H10	4221 0021 00	10	3/8
	H13	4221 0020 01	13	1/2		H13	4221 0021 01	13	1/2
	H16	4221 0020 02	16	5/8		H16	4221 0021 02	16	5/8
	H20	4221 0020 03	19	3/4		H20	4221 0021 03	19	3/4
<b>M – Male thread</b> 	M10	4221 0020 04	3/8	BSPT	<b>M – Male</b> 	M10	4221 0021 04	3/8	BSPT
	M15	4221 0020 05	1/2	BSPT		M15	4221 0021 05	1/2	BSPT
	M20	4221 0020 06	3/4	BSPT		M20	4221 0021 06	3/4	BSPT
<b>F – Female thread</b> 	F10	4221 0020 07	3/8	BSP	<b>F – Female</b> 	F10	4221 0021 07	3/8	BSP
	F15	4221 0020 08	1/2	BSP		F15	4221 0021 08	1/2	BSP
	F20	4221 0020 09	3/4	BSP		F20	4221 0021 09	3/4	BSP

# Euro standard 15 mm

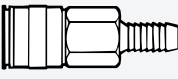
## QIC 15 AND NIP 15, 30 L/S (recommended air flow at 6.3 bar pressure)

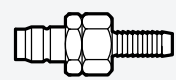
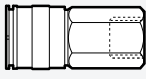
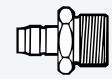
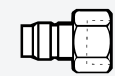
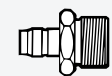
Connection type	Coupling QIC 15	Ordering No.	Size		Connection type	Nipple NIP 15	Ordering No.	Size	
			mm	in				mm	in
<b>H – Hose</b> 	H10	8202 1304 00	10	3/8	<b>H – Hose</b> 	H06	8202 1251 03	6.3	1/4
	H13	8202 1304 18	12.5	1/2		H08	8202 1252 28	8	5/16
	H16	8202 1304 26	16	5/8		H10	8202 1251 11	10	3/8
<b>M – Male thread</b> 	M08	8202 1304 34	1/4	BSP	<b>SH – Safety Hose<sup>a</sup></b> 	SH10	8202 1203 44	10	3/8
	M10	8202 1304 42	3/8	BSP		SH13	8202 1203 51	12.5	1/2
	M15	8202 1304 59	1/2	BSP		SH16	8202 1203 69	16	5/8
<b>F – Female thread</b> 	F15	8202 1304 67	1/2	BSP	<b>M – Male thread /</b> 	M10	8202 1251 45	3/8	BSP
						M15	8202 1251 52	1/2	BSP
<b>F – Female thread</b> 	F08	8202 1251 94	1/4	BSP	<b>MT – Male taper thread</b> 	MT08	8202 1251 60	1/4	BSPT
	F10	8202 1252 02	3/8	BSP		MT10	8202 1251 78	3/8	BSPT
	F15	8202 1252 10	1/2	BSP		MT15	8202 1251 86	1/2	BSPT

<sup>a</sup> For hoses longer than 3 meters.

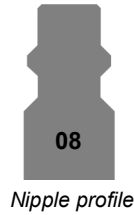

### ErgoQIC 08US

#### ISO 6150-B / US STANDARD

The ErgoQIC 08US is a full flow quick coupling with no air restriction inside the coupling suitable for assembly tools, drills and small grinders. Upgrading any air system with ErgoQIC 08US will give the benefit of productivity and energy efficiency.

- Full flow coupling.
- Ergonomic design, small size and low weight.
- Strong and durable.
- Safety feature according to EN 983 / ISO 4414.
- Main market: North America, France, Norway and Spain.

#### Technical Data

Max flow capacity	17 l/s (0.5 bar ΔP)
Economical air flow	11 l/s (0.2 bar ΔP)
Max working pressure	16 bar
Temperature range	-20°C to 80°C

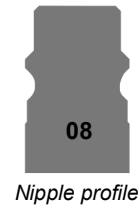

### SmartQIC 08US

#### ISO 6150-B / US STANDARD

Safety coupling with venting connection, high flow and low pressure drop.

- High reliability with low pressure drop.
- Safety function with vented connection.
- High durability and easy handling.
- High air flow and increased productivity.
- Minimizes hose whip and injuries to operator.
- Long life time.
- Safety feature according to ISO-standard 4414 and EN 983.
- Main market: Benelux, France, Norway and North America.

#### Technical Data

Max flow capacity	16 l/s (0.5 bar ΔP)
Economical air flow	15 l/s (0.2 bar ΔP)
Max working pressure	16 bar
Temperature range	-20°C to +100°C

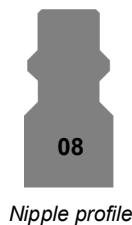

### QIC 08US

#### ISO 6150-B / US STANDARD

The QIC 08US coupling is suitable for small screwdrivers and drills. Its lightweight, compact design makes the QIC 08US coupling easy to work with.

- High flow coupling.
- One-hand operation.
- Low connection force.
- Main market: North America, France, Norway and Spain.

#### Technical Data

Max flow capacity	12 l/s (0.5 bar ΔP)
Economical air flow	8 l/s (0.2 bar ΔP)
Max working pressure	16 bar
Temperature range	-20°C to +80°C



# Quick Couplings

# ISO 6150-B / US Standard 5.3 mm (1/4")

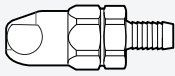
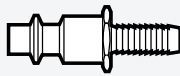
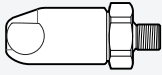
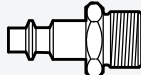
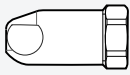
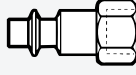

## ERGOQIC 08US AND NIP 08, 11 L/S (recommended air flow at 6.3 bar pressure)

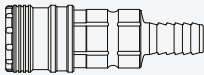
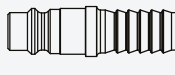
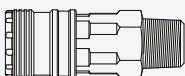
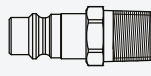
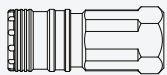
Connection type	Coupling ErgoQIC 08US	Ordering No.	Size		Connection type	Nipple NIP 08	Ordering No.	Size	
			mm	in				mm	in
<b>H – Hose</b> 	H06	8202 1103 00	6.3	1/4	<b>H – Hose</b> 	H06	8202 1205 18	6.3	1/4
	H08	8202 1103 01	8	5/16		H08	8202 1205 26	8	5/16
	H10	8202 1103 02	10	3/8		H10	8202 1205 34	10	3/8
						H13	8202 1208 03	12.5	1/2
<b>M – Male</b> 	M08	8202 1103 05	1/4	BSP	<b>M – Male</b> 	M06	8202 1205 42	1/8	BSP
	M10	8202 1103 07	3/8	BSP		M08	8202 1205 59	1/4	BSP
	M15	8202 1103 09	1/2	BSP		M10	8202 1205 67	3/8	BSP
<b>F – Female</b> 	F08	8202 1103 11	1/4	BSP	<b>F – Female</b> 	F08	8202 1205 83	1/4	BSP
	F10	8202 1103 13	3/8	BSP		F10	8202 1205 91	3/8	BSP

## SMARTQIC 08US AND NIP-08US, 15 L/S (recommended air flow at 6.3 bar pressure)

Connection type	Coupling SmartQIC 08US	Ordering No.	Size		Connection type	Nipple NIP 08US	Ordering No.	Size	
			mm	in				mm	in
<b>H – Hose</b> 	H06	4221 0030 00	6.3	1/4	<b>H – Hose</b> 	H06	4221 0031 00	6.3	1/4
	H08	4221 0030 01	8	5/16		H08	4221 0031 01	8	5/16
	H10	4221 0030 02	10	3/8		H10	4221 0031 02	10	3/8
<b>M – Male thread</b> 	M10	4221 0030 03	3/8	BSP	<b>M – Male thread</b> 	M06	4221 0031 03	1/4	BSP
	M15	4221 0030 04	1/2	BSP		M10	4221 0031 04	3/8	BSP
	M10	4221 0030 05	3/8	NPT		M06	4221 0031 05	1/4	NPT
	M15	4221 0030 06	1/2	NPT		M10	4221 0031 06	3/8	NPT
<b>F – Female thread</b> 	F06	4221 0030 07	1/4	BSP	<b>F – Female thread</b> 	F06	4221 0031 07	1/4	BSP
	F10	4221 0030 08	3/8	BSP		F10	4221 0031 08	3/8	BSP
	F06	4221 0030 09	1/4	NPT		F06	4221 0031 09	1/4	NPT
	F10	4221 0030 10	3/8	NPT		F10	4221 0031 10	3/8	NPT

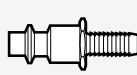
## QIC 08 AND NIP 08, 8 L/S (recommended air flow at 6.3 bar pressure)

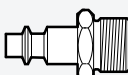
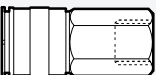
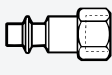
Connection type	Coupling QIC 08	Ordering No.	Size		Connection type	Nipple NIP 08	Ordering No.	Size	
			mm	in				mm	in
<b>H – Hose</b> 	H06	8202 1300 04	6.3	1/4	<b>H – Hose</b> 	H06	8202 1205 18	6.3	1/4
	H08	8202 1300 12	8	5/16		H08	8202 1205 26	8	5/16
	H10	8202 1300 20	10	3/8		H10	8202 1205 34	10	3/8
<b>M – Male thread</b> 	M08	8202 1300 38	1/4	BSP	<b>M – Male thread</b> 	M06	8202 1205 42	1/8	BSP
	M10	8202 1300 46	3/8	BSP		M08	8202 1205 59	1/4	BSP
						M10	8202 1205 67	3/8	BSP
<b>F – Female thread</b> 	F08	8202 1300 53	1/4	BSP	<b>F – Female thread</b> 	F08	8202 1205 83	1/4	BSP
	F10	8202 1300 61	3/8	BSP		F10	8202 1205 91	3/8	BSP

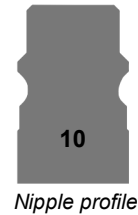
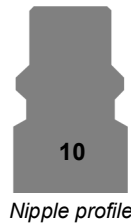

### ErgoQIC 10US

#### ISO 6150-B / US STANDARD

The ErgoQIC 10US is a full flow quick coupling with no air restriction inside the coupling suitable for assembly tools, drills and small grinders. Upgrading any air system with ErgoQIC 10US couplings will give the benefit of productivity and energy efficiency. It is interchangeable with US 3/8" standard nipples.

- Full flow coupling.
- Ergonomic design, small size and low weight.
- Strong and durable.
- Safety feature according to EN 983 / ISO 4414.
- Main market: North America, France, Norway and Spain.

#### Technical Data

Max flow capacity	43 l/s (0.5 bar ΔP)
Economical air flow	27 l/s (0.2 bar ΔP)
Max working pressure	16 bar
Temperature range	-20°C to 80°C

### SmartQIC 10US

#### ISO 6150-B / US STANDARD

Safety coupling with venting connection, high flow and low pressure drop.



- High reliability with low pressure drop.
- Safety function with vented connection.
- High durability and easy handling.
- High air flow and increased productivity.
- Minimizes hose whip and injuries to operator.
- Long life time.
- Safety feature according to ISO-standard 4414 and EN 983.
- Main market: Benelux, France, Norway and North America.

#### Technical Data

Max flow capacity	43 l/s (0.5 bar ΔP)
Economical air flow	39 l/s (0.2 bar ΔP)
Max working pressure	16 bar
Temperature range	-20°C to +100°C

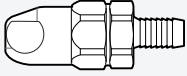
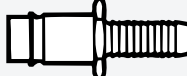
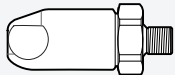

### ERGOQIC 10US AND NIP 10US, 27 L/S (recommended air flow at 6.3 bar pressure)

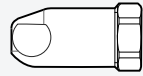
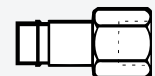
Connection type	Coupling ErgoQIC 10US	Ordering No.	Size		Connection type	Nipple NIP 10US	Ordering No.	Size	
			mm	in				mm	in
<b>H – Hose</b> 	H08	8202 1107 01	8	5/16	<b>H – Hose</b> 	H08	8202 1210 70	8	5/16
	H10	8202 1107 02	10	3/8		H10	8202 1210 71	10	3/8
	H13	8202 1107 03	12.5	1/2		H13	8202 1210 72	12.5	1/2
	H20	8202 1107 05	19	3/4		H16	8202 1210 73	16	5/8
						H20	8202 1210 74	19	3/4
<b>M – Male</b> 	M08	8202 1107 07	1/4 BSP		<b>M – Male</b> 	M08	8202 1210 75	1/4 BSP	
	M10	8202 1107 09	3/8 BSP			M10	8202 1210 76	3/8 BSP	
	M15	8202 1107 11	1/2 BSP			M15	8202 1210 77	1/2 BSP	
<b>F – Female</b> 	F08	8202 1107 13	1/4 BSP		<b>F – Female</b> 	F08	8202 1210 81	1/4 BSP	
	F10	8202 1107 15	3/8 BSP			F10	8202 1210 82	3/8 BSP	
	F15	8202 1107 17	1/2 BSP			F15	8202 1210 83	1/2 BSP	

### SMARTQIC 10US AND NIP-10US, 39 L/S (recommended air flow at 6.3 bar pressure)

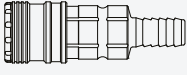
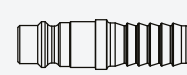
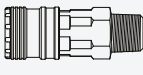
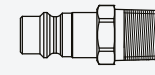
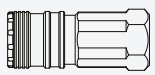
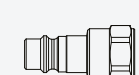
Connection type	Coupling SmartQIC 10US	Ordering No.	Size		Connection type	Nipple NIP 10US	Ordering No.	Size	
			mm	in				mm	in
<b>H – Hose</b> 	H10	4221 0050 00	10	3/2	<b>H – Hose</b> 	H08	4221 0051 00	8	5/16
	H13	4221 0050 01	13	1/2		H10	4221 0051 01	10	3/8
						H13	4221 0051 02	13	1/2
<b>M – Male thread</b> 	M10	4221 0050 02	3/8 BSPT		<b>M – Male thread</b> 	M06	4221 0051 03	1/4 BSP	
	M15	4221 0050 03	1/2 BSPT			M10	4221 0051 04	3/8 BSP	
	M10	4221 0050 04	3/8 NPT			M15	4221 0051 05	1/2 BSP	
	M15	4221 0050 05	1/2 NPT			M06	4221 0051 06	1/4 NPT	
<b>F – Female thread</b> 	F10	4221 0050 06	3/8 BSP		<b>F – Female thread</b> 	M10	4221 0051 07	3/8 NPT	
	F15	4221 0050 07	1/2 BSP			M15	4221 0051 08	1/2 NPT	
	F10	4221 0050 08	3/8 NPT			F06	4221 0051 09	1/4 BSP	
	F15	4221 0050 09	1/2 NPT			F10	4221 0051 10	3/8 BSP	
						F15	4221 0051 11	1/2 BSP	
						F06	4221 0051 12	1/4 NPT	
						F10	4221 0051 13	3/8 NPT	
						F15	4221 0051 14	1/2 NPT	

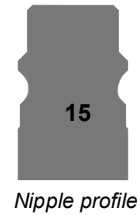
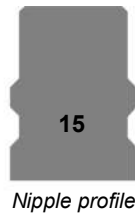

### ErgoQIC 15US

#### ISO 6150-B / US STANDARD

The ErgoQIC 15US is a full flow coupling with no air restriction inside the coupling suitable for large air consuming assembly tools, drills and grinders. Upgrading any air system with ErgoQIC 15US will give the benefit of productivity and energy efficiency. It is interchangeable with US 1/2" standard nipples.

- Extreme full flow coupling.
- Strong and durable.
- Minimized connection force.
- Safety feature according to EN 983 / ISO 4414.
- Main market: North America, France, Norway and Spain.

### SmartQIC 15US

#### ISO 6150-B / US STANDARD

Safety coupling with venting connection, high flow and low pressure drop.

- High reliability with low pressure drop.
- Safety function with vented connection.
- High durability and easy handling.
- High air flow and increased productivity.
- Minimizes hose whip and injuries to operator.
- Long life time.
- Safety feature according to ISO-standard 4414 and EN 983.
- Main market: North America, France, Norway and Spain.



### Technical Data

Max flow capacity	77 l/s (0.5 bar ΔP)
Economical air flow	52 l/s (0.2 bar ΔP)
Max working pressure	16 bar
Temperature range	-20°C to +80°C

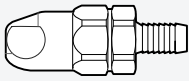

### Technical Data

Max flow capacity	69 l/s (0.5 bar ΔP)
Economical air flow	64 l/s (0.2 bar ΔP)
Max working pressure	16 bar
Temperature range	-20°C to +100°C

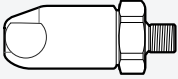
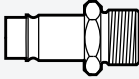
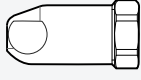
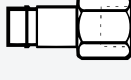
### ERGOQIC 15US AND NIP 15US, 52 L/S (recommended air flow at 6.3 bar pressure)

Connection type	Coupling ErgoQIC 15US	Ordering No.	Size		Connection type	Nipple NIP 15US	Ordering No.	Size	
			mm	in				mm	in
<b>H – Hose</b> 	H10	8202 1108 02	10	3/8	<b>H – Hose</b> 	H10	8202 1215 40	10	3/8
	H13	8202 1108 03	12.5	1/2		H13	8202 1215 41	12.5	1/2
	H16	8202 1108 04	16	5/8		H16	8202 1215 42	16	5/8
	H20	8202 1108 05	19	3/4		H20	8202 1215 43	19	3/4
<b>M – Male</b> 	M10	8202 1108 09	3/8 BSP	<b>M – Male</b> 	M08	8202 1215 44	1/4 BSP		
	M15	8202 1108 11	1/2 BSP		M10	8202 1215 45	3/8 BSP		
<b>F – Female</b> 	F10	8202 1108 15	3/8 BSP	<b>F – Female</b> 	F10	8202 1215 52	3/8 BSP		
	F15	8202 1108 17	1/2 BSP		F15	8202 1215 53	1/2 BSP		

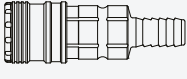
### SMARTQIC 15US AND NIP 15US, 8 L/S (recommended air flow at 6.3 bar pressure)

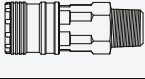
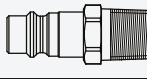
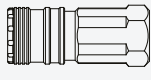
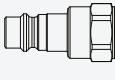
Connection type	Coupling SmartQIC 15US	Ordering No.	Size		Connection type	Nipple NIP 15US	Ordering No.	Size	
			mm	in				mm	in
<b>H – Hose</b> 	H13	4221 0040 00	13	1/2	<b>H – Hose</b> 	H10	4221 0041 00	10	3/8
	H20	4221 0040 02	19	3/4		H13	4221 0041 01	13	1/2
<b>M – Male thread</b> 	M10	4221 0040 03	3/8 NPT	<b>M – Male thread</b> 	M10	4221 0041 04	3/8 NPT		
	M15	4221 0040 04	1/2 NPT		M15	4221 0041 05	1/2 NPT		
	M20	4221 0040 05	3/4 NPT		M20	4221 0041 06	3/4 NPT		
<b>F – Female thread</b> 	F10	4221 0040 06	3/8 NPT	<b>F – Female thread</b> 	F10	4221 0041 07	3/8 NPT		
	F15	4221 0040 07	1/2 NPT		F15	4221 0041 08	1/2 NPT		
	F20	4221 0040 08	3/4 NPT		F20	4221 0041 09	3/4 NPT		

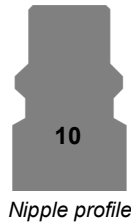

Nipple profile

## ErgoQIC 10AC

### ATLAS COPCO GLOBAL STANDARD

The ErgoQIC 10AC is a full flow quick coupling with no air restriction inside the coupling suitable for assembly tools, drills and small grinders. Upgrading any air system with ErgoQIC 10AC will give the benefit of productivity and energy efficiency.

- Full flow coupling.
- Ergonomic design, small size and low weight.
- Strong and durable.
- Safety feature according to EN 983 / ISO 4414.
- Main market: Nordic, Benelux and Italy.

### Technical Data

Max flow capacity	26 l/s (0.5 bar ΔP)
Economical air flow	17 l/s (0.2 bar ΔP)
Max working pressure	16 bar
Temperature range	-10°C to +70°C



Nipple profile

## QIC 10

### ATLAS COPCO GLOBAL STANDARD







The QIC 10 is a small quick coupling suitable for assembly tools and drills. The QIC 10 can withstand extremely rough handling in tough applications.

- High flow coupling.
- Strong and durable.
- One-hand operation.
- Main market: Europe and Australia.

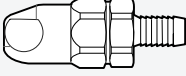

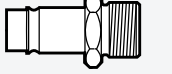
### Technical Data

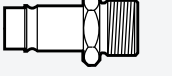
Max flow capacity	24 l/s (0.5 bar ΔP)
Economical air flow	15 l/s (0.2 bar ΔP)
Max working pressure	16 bar
Temperature range	-20°C to +80°C

### ERGOQIC 10AC AND NIP 10, 17 L/S (recommended air flow at 6.3 bar pressure)

Connection type	Coupling ErgoQIC 10AC	Ordering No.	Size		Connection type	Nipple NIP 10	Ordering No.	Size	
			mm	in				mm	in
<b>H – Hose</b> 	H08	8202 1109 01	8	5/16	<b>H – Hose</b> 	H06	8202 1202 11	6.3	3/8
	H10	8202 1109 02	10	3/8		H08	8202 1202 94	8	1/2
	H13	8202 1109 03	12.5	1/2		H10	8202 1202 29	10	5/8
						H13	8202 1202 34	12.5	3/4
<b>M – Male thread</b> 	M08	8202 1109 05	1/4	BSP	<b>M – Male thread</b> 	M06	8202 1202 37	1/8	BSP
	M10	8202 1109 06	3/8	BSP		M08	8202 1202 45	1/4	BSP
	M15	8202 1109 07	1/2	BSP		M10	8202 1202 52	3/8	BSP
<b>F – Female</b> 	F08	8202 1109 09	1/4	BSP	<b>MT – Male taper thread</b> 	MT08	8202 1202 60	1/4	BSPT
	F10	8202 1109 10	3/8	BSP		MT10	8202 1202 78	3/8	BSPT
	F15	8202 1109 11	1/2	BSP		MT15	8202 1203 02	1/2	BSPT
					<b>F – Female</b> 	F08	8202 1202 86	1/4	BSP
						F10	8202 1202 87	3/8	BSP

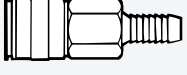
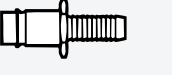
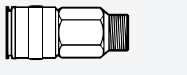
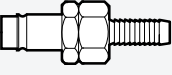
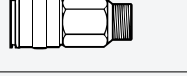
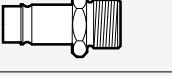
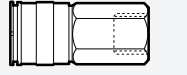
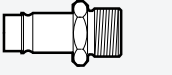
### QIC 10 AND NIP 10, 15 L/S (recommended air flow at 6.3 bar pressure)

Connection type	Coupling QIC 10	Ordering No.	Size		Connection type	Nipple NIP 10	Ordering No.	Size	
			mm	in				mm	in
<b>H – Hose</b> 	H06	8202 1302 02	6.3	1/4	<b>H – Hose</b> 	H06	8202 1202 11	6.3	1/4
	H08	8202 1302 10	8	5/16		H08	8202 1202 94	8	5/16
	H10	8202 1302 28	10	3/8		H10	8202 1202 29	10	3/8
	H13	8202 1302 34	12.5	1/2		H13	8202 1202 34	12.5	1/2
<b>M – Male thread</b> 	M08	8202 1302 36	1/4	BSP	<b>SH – Safety Hose <sup>a</sup></b> 	SH06	8202 1203 10	6.3	1/4
	M10	8202 1302 44	3/8	BSP		SH08	8202 1203 36	8	5/16
						SH10	8202 1203 28	10	3/8
<b>MT – Male taper thread</b> 	MT15	8202 1302 51	1/2	BSPT	<b>M – Male thread</b> 	M06	8202 1202 37	1/8	BSP
						M08	8202 1202 45	1/4	BSP
						M10	8202 1202 52	3/8	BSP
<b>F – Female</b> 	F08	8202 1302 69	1/4	BSP	<b>MT – Male taper thread</b> 	MT08	8202 1202 60	1/4	BSPT
						MT10	8202 1202 78	3/8	BSPT
						MT15	8202 1203 02	1/2	BSPT
					<b>F – Female</b> 	F08	8202 1202 86	1/4	BSP
						F10	8202 1202 87	3/8	BSP

<sup>a</sup>For hoses longer than 3 meters.

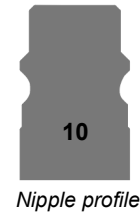
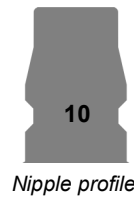

## ErgoQIC 10A

### ASIA STANDARD 7.5 MM

The ErgoQIC 10 ASIA is a full flow coupling with no air restriction inside the coupling. It is suitable for assembly tools, drills and grinders. Upgrading any air system with ErgoQIC 10 ASIA will give the benefits of productivity and energy efficiency.

- Extreme full flow coupling.
- Strong and durable.
- Minimized connection force.
- Safety feature according to EN 983 / ISO 4414.
- Main market: Asia, Australia, Italy and South America.

### Technical Data

Max flow capacity	35 l/s (0.5 bar ΔP)
Economical air flow	22 l/s (0.2 bar ΔP)
Max working pressure	16 bar
Temperature range	-10°C to +70°C

## SmartQIC 10A

### ASIA STANDARD 7.5 MM



Safety coupling with venting connection, high flow and low pressure drop.

- High reliability with low pressure drop.
- Safety function with vented connection.
- High durability and easy handling.
- High air flow and increased productivity.
- Minimizes hose whip and injuries to operator.
- Long life time.
- Safety feature according to ISO-standard 4414 and EN 983.
- Main market: Asia, Australia, Italy and South America.

### Technical Data

Max flow capacity	33 l/s (0.5 bar ΔP)
Economical air flow	32 l/s (0.2 bar ΔP)
Max working pressure	16 bar
Temperature range	-20°C to +100°C

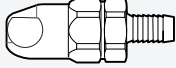
### ERGOQIC 10 A AND NIP 10 A, 22 L/S (recommended air flow at 6.3 bar pressure)

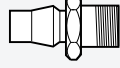
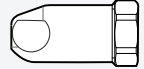
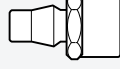
Connection type	Coupling ErgoQIC 10 A	Ordering No.	Size		Connection type	Nipple NIP 10 A	Ordering No.	Size	
			mm	in				mm	in
<b>H – Hose</b> 	H06	8202 1104 00	6.3	1/4	<b>H – Hose</b> 	H06	8202 1202 15	6.3	1/4
	H08	8202 1104 01	8	5/16		H08	8202 1202 16	8	5/16
	H10	8202 1104 02	10	3/8		H10	8202 1202 17	10	3/8
	H13	8202 1104 03	12.5	1/2		H13	8202 1202 18	12.5	1/2
<b>MT – Male taper thread</b> 	MT08	8202 1104 05	1/4	BSPT	<b>MT – Male taper thread</b> 	MT06	8202 1202 19	1/8	BSPT
	MT10	8202 1104 06	3/8	BSPT		MT08	8202 1202 20	1/4	BSPT
	MT15	8202 1104 07	1/2	BSPT		MT10	8202 1202 21	3/8	BSPT
<b>FT – Female taper thread</b> 	FT08	8202 1104 09	1/4	BSPT	<b>FT – Female taper thread</b> 	FT08	8202 1202 23	1/4	BSPT
	FT10	8202 1104 10	3/8	BSPT		FT10	8202 1202 24	3/8	BSPT
	FT15	8202 1104 11	1/2	BSPT		FT15	8202 1202 25	1/2	BSPT

### SMARTQIC 10A AND NIP 10A, 32 L/S (recommended air flow at 6.3 bar pressure)

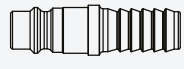
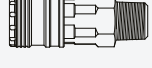
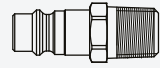
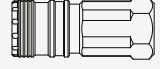
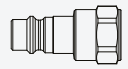



Connection type	Coupling SmartQIC 10A	Ordering No.	Size		Connection type	Nipple NIP 10A	Ordering No.	Size	
			mm	in				mm	in
<b>H – Hose</b> 	H06	4221 0060 00	6.3	1/4	<b>H – Hose</b> 	H06	4221 0061 00	6.3	1/4
	H08	4221 0060 01	7	9/32		H08	4221 0061 01	7	9/32
	H10	4221 0060 02	10	3/8		H10	4221 0061 02	10	3/8
<b>M – Male thread</b> 	M06	4221 0060 03	1/4	BSP	<b>M – Male thread</b> 	M06	4221 0061 04	1/4	BSP
	M10	4221 0060 04	3/8	BSP		M10	4221 0061 05	3/8	BSP
	M15	4221 0060 05	1/2	BSP		M15	4221 0061 06	1/2	BSP
<b>F – Female thread</b> 	F06	4221 0060 06	1/4	BSP	<b>F – Female thread</b> 	F06	4221 0061 07	1/4	BSP
	F10	4221 0060 07	3/8	BSP		F10	4221 0061 08	3/8	BSP
	F15	4221 0060 08	1/2	BSP		F15	4221 0061 09	1/2	BSP

CLAW couplings are made from drop-forged, hardened steel which can withstand rough treatment and ensures a long life even under difficult conditions. The coupling head is the same for all sizes, which can therefore be freely combined.

The recommended maximum working pressure is 10 bar.

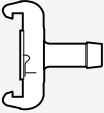
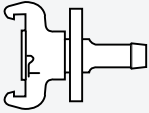
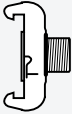
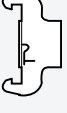
- Large bore – machined surfaces give low air resistance and minimum pressure drop.
- Robust claws – will withstand rough handling without deformation.
- Locking lugs – precision-made to provide a reliable lock.
- Special rubber packings – resistant to oil and temperature changes. Max. temperature 80°C (176°F).
- Packing seats – lathe-turned grooves ensure a leak-proof seal.
- Couplings are zinc-plated and thus effectively treated against corrosion.
- Available with extra protective cover.



Connection type	Coupling CLAW	Ordering No.	Size		Bore B, mm
			mm	in	
<b>H – Hose</b> 	H06	9000 0308 00	6.3	1/4	5.0
	H10	9000 0309 00	10	3/8	8.0
	H13	9000 0310 00	12.5	1/2	10.5
	H16	9000 0311 00	16	5/8	13.5
	H20	9000 0312 00	19	3/4	17.0
	H25	9000 0313 00	25	1	22.0
<b>LNH – Lock nut, Hose</b> 	LNH10	9000 0260 00	10	3/8	8.0
	LNH13	9000 0261 00	12.5	1/2	10.5
	LNH16	9000 0262 00	16	5/8	13.5
	LNH20	9000 0263 00	19	3/4	17.2
	LNH25	9000 0264 00	25	1	22.0
<b>M – Male thread</b> 	M10	9000 0300 00		3/8 BSP	11.2
	M15	9000 0301 00		1/2 BSP	14.8
	M20	9000 0302 00		3/4 BSP	19.0
	M25	9000 0303 00		1 BSP	25.5
<b>F – Female thread</b> 	F10	9000 0304 00		3/8 BSP	15.0
	F15	9000 0305 00		1/2 BSP	18.6
	F20	9000 0306 00		3/4 BSP	24.0
	F25	9000 0307 00		1 BSP	25.0
Protection cover for CLAW couplings		9000 0314 00			
Extra packing for CLAW couplings		For type H, M and F	9000 0000 00 (+80°C), 9000 0000 01 (+200°C) <sup>a</sup>		
		For LNH10, -13 and -16	9000 0015 00		
		For LNH20 and -25	9000 0268 00 (+80°C), 9000 0319 00 (+200°C) <sup>a</sup>		
Safety lock spring		3176 8640 90	25 pieces		

<sup>a</sup> Viton-green.



## BAL AND BAL-1A

The Atlas Copco valves BAL and BAL-1A are both suitable for air, water and many other liquids and gases due to the choice of material.

- Silicone-free grease – Both are lubricated with silicone-free grease which is important when spray-painting.
- Maximum through flow – Full bore valve to DIN standards.
- Housing and ball made of chrome-plated hot-stamped brass MS 58.
- Handle of enamelled aluminum.

## BAL – WITH NITRILE RUBBER SEALS

BAL valves can be used in all settings between fully open and fully closed.

The balls and the seals can be replaced without the body being removed from the piping.

## BAL-1A – WITH TEFLON SEALS

Intended for operating either fully open or fully closed.



Model	Connection thread in BSP	Bore D mm	L mm	H mm	I mm	Ordering No.
BAL 08	1/4	9.5	50	41	-	8202 0301 05
BAL 10	3/8	9.5	50	41	-	8202 0302 04
BAL 15	1/2	12.5	60	43	-	8202 0303 03
BAL 20	3/4	19	75	55	-	8202 0304 02
BAL 25	1	24.5	90	64	-	8202 0305 01
BAL-1A 08	1/4	8	43	44	73	8202 0306 03
BAL-1A 10	3/8	10	50	47	73	8202 0306 11
BAL-1A 15	1/2	15	61	53	94	8202 0306 29
BAL-1A 20	3/4	20	70	57	94	8202 0306 37
BAL-1A 25	1	25	83	67.5	122	8202 0306 45
BAL-1A 32	1 1/4	32	100	83	150	8202 0306 52
BAL-1A 40	1 1/2	38	107	87	150	8202 0306 60
BAL-1A 50	2	50	129	103	193	8202 0306 78

## Technical data

### BAL

Maximum working pressure: 16 bar.

Working temperature range: -20°C to +90°C.

### BAL-1A

Maximum working pressure: 16 bar (BAL-1A 40 and 50: max. 16 bar up to +100°C).

Working temperature range: -30°C to +200°C. (BAL-1A 40 and 50: at +200°C max. working pressure is reduced to 8 bar).

## Dimensions

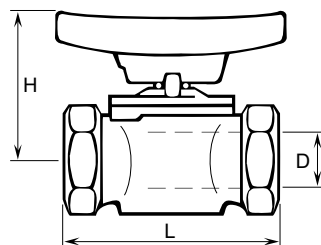

BAL

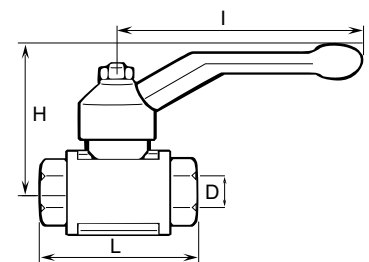

BAL-1A

**MULTIFLEX SWIVEL  
MULTI-DIRECTIONAL CONNECTOR**

The MultiFlex swivel is an ingenious multi-directional connector. Connect your tool and the hose will stay in the ideal position however much you and the tool move around. The MultiFlex bends and rotates 360° in all directions while the hose stays straight. It takes the effort out of working in those cramped spaces. What's more, the hose feels almost weightless and it reduces hose wear. It's the magic of MultiFlex – a marriage of ergonomic thinking and ingenious design.

- Ergonomic.
- Reduces hose wear.
- High flow capacity.
- Minimum pressure drop.
- Strong and durable.
- Available with rubber (EPDM) protective cover.
- Fits most pneumatic tools.



Model	Max rec. air flow <sup>a</sup>		Thread		Weight g	Length mm	Dia mm	Ordering No.
	l/s	cfm	Inlet female in	Outlet male in				
<b>Standard</b>								
MultiFlex 1/8" BSP	12	25	1/8	1/8	73	66.2	24	8202 1350 18
MultiFlex 1/4" BSP	12	25	1/4	1/4	73	66.2	24	8202 1350 20
MultiFlex 3/8" BSP	32	68	3/8	3/8	130	80.6	29.5	8202 1350 22
MultiFlex 1/2" BSP	32	68	1/2	1/2	125	80.6	29.5	8202 1350 24
<b>Protective rubber cover</b>								
MultiFlex 1/8" BSP	12	25	1/8	1/8	76	66.2	27	8202 1350 40
MultiFlex 1/4" BSP	12	25	1/4	1/4	76	66.2	27	8202 1350 41
MultiFlex 3/8" BSP	32	68	3/8	3/8	130	80.6	29.5	8202 1350 42
<b>High air flow</b>								
MultiFlex 1/2" BSP	54	114	1/2	1/2	326	98.3	39	8202 1350 60

The pressure drop will be 0.2 bar at an inlet pressure of 6 bar.



## SIMPLE PRESSURE CLAMPS FOR PVC HOSES

For CABLAIR	For PVC	One-lugged steel clamp mm	Ordering No.
-	-	5.2- 6.2	0347 0122 18
-	-	5.9- 7.0	0347 0122 19
-	03	7.0- 8.5	0347 0122 05
06	05	8.5-10.0	0347 0122 06
08	06	9.8-11.8	0347 0122 07
-	08	11.3-13.3	0347 0122 08
10	-	12.8-14.8	0347 0122 09
-	10	14.6-16.8	0347 0122 10
13	-	16.5-18.8	0347 0122 11
-	13	18.0-20.3	0347 0122 12
16	-	20.2-22.8	0347 0122 13
-	-	22.0-24.8	0347 0122 14
20	-	23.3-26.3	0347 0122 15
-	-	26.5-30.0	0347 0122 16
25	-	29.8-33.1	0347 0122 22



## MEDIUM PRESSURE CLAMPS FOR PVC HOSES

For CABLAIR	For PVC, POLUR	Medium clamp worm drive mm	Ordering No.
-	-	8.0-14.0	0347 6102 00
-	08	11.0-17.0	0347 6103 00
-	10	11.0-17.0	0347 6103 00
-	-	13.0-20.0	0347 6104 00
16	13	15.0-24.0	0347 6105 00
20	16	19.0-28.0	0347 6106 00
-	20	22.0-32.0	0347 6107 00
25	25	26.0-38.0	0347 6109 00
-	-	32.0-44.0	0347 6111 00
-	-	38.0-50.0	0347 6112 00
-	-	50.0-65.0	0347 6113 00



## MEDIUM PRESSURE CLAMPS FOR RUBBER HOSES

For TURBO	For RUBAIR	Medium clamp worm drive mm	Ordering No.
-	06	11.0-17.0	0347 6103 00
13	10	13.0-20.0	0347 6104 00
16	13	15.0-24.0	0347 6105 00
-	16	19.0-28.0	0347 6106 00
20	-	22.0-32.0	0347 6107 00
-	20	26.0-38.0	0347 6109 00



## HEAVY-DUTY PRESSURE CLAMPS FOR RUBBER HOSES

For TURBO	For RUBAIR	Heavy-duty clamp mm	Ordering No.
-	-	22.0-25.0	9000 0194 00
20	16	25.0-28.0	9000 0195 00
-	20	29.0-32.0	9000 0196 00
-	25	34.0-38.0	9000 0197 00



## HOSE CONNECTION

Male thread – hose nipple

Thread in	Hose size		Ordering No.
	mm	in	
1/8 BSP	3.2	1/8	9000 0523 00
1/8 BSPT	5	3/16	4010 0031 00
1/8 BSPT	6.3	1/4	9000 0240 00
1/4 BSP	3.2	1/8	9000 0524 00
1/4 BSPT	6.3	1/4	9000 0241 00
1/4 BSPT	8	5/16	9090 1715 00
1/4 BSPT	10	3/8	9000 0247 00
3/8 BSPT	10	3/8	9000 0248 00
3/8 BSPT	12.5	1/2	9000 0248 00
1/2 BSPT	12.5	1/2	9000 0243 00
1/2 BSPT	16	5/8	9000 0244 00
1/2 BSP	20	3/4	4150 0429 00
3/4 BSPT	20	3/4	9000 0245 00
1 BSPT	25	1	9000 0246 00



## GASKETS

For couplings with male parallel thread	Fiber gasket between material and nipple Ordering No.
1/8 BSP	0657 5742 00
1/4 BSP	0657 5764 00
3/8 BSP	0657 5785 00
1/2 BSP	0653 0500 01
3/4 BSP	0657 5823 00
1 BSP	0657 5830 00



## REDUCING NIPPLE IN BRASS

Female thread in	Male thread in	Ordering No.
1/4 BSP	1/8 BSP	9721 4000 94
3/8 BSP	1/4 BSP	9721 4000 92
1/2 BSP	3/8 BSP	9721 4000 93



## SWIVELS

Air inlet	Air outlet Male BSP	Max Swivel bend from centre line	Ordering No.
5/16" hose	1/4	30°	4210 3134 80

Recommended flow max 10 l/s

# Fittings

## BUSHING

Male thread – female thread



Male thread in	Female thread in	Ordering No.
1/4 BSP	1/8 BSP	9090 0799 00
3/8 BSP	1/4 BSP	9090 0798 00
1/2 BSP	1/4 BSP	9090 1469 00
1/2 BSP	3/8 BSP	9090 0797 00
3/4 BSP	1/2 BSP	9090 0796 00
1 BSPT	3/4 BSP	9090 0795 00

## DOUBLE CONNECTION

Male taper thread – male taper thread



From thread in	To thread in	Ordering No.
1/8 BSPT	1/8 BSPT	9090 0100 00
1/8 BSPT	1/4 BSPT	9090 0110 00
1/4 BSPT	1/4 BSPT	9090 0120 00
1/4 BSPT	3/8 BSPT	9090 0130 00
3/8 BSPT	3/8 BSPT	9090 0140 00
3/8 BSPT	1/2 BSPT	9090 0150 00
1/2 BSPT	1/2 BSPT	9090 0160 00
1/2 BSPT	3/4 BSPT	9090 0170 00
3/4 BSPT	3/4 BSPT	9090 0180 00
3/4 BSPT	1 BSPT	9090 0190 00
1 BSPT	1 BSPT	9090 0200 00

## DOUBLE ADJUSTABLE CONNECTION

Male thread – male thread



From thread in	To thread in	Ordering No.
1/2 BSP	1/2 BSP	9090 0806 00

## SEALING RINGS FOR DOUBLE ADJUSTABLE CONNECTION



For coupling with male thread in	Spare rubber sealing ring for adjustable connections Ordering No.
1/2 BSP	9090 0884 00
1 BSP	9090 0886 00

## HOSE CONNECTION WITH CLAMP NUT AND SPRING GUARD



### 1 Clamp nut, brass

Hose diameter Outside/Inside mm	Male thread in	Ordering No.
10/8	1/4 BSP	9721 4002 89
12/10	3/8 BSP	9721 4000 88
15/12.5	1/2 BSP	9721 4000 89

Male threaded hose nipple with clamp nut should be used with female threaded quick couplings.

### 2 Spring guard in steel

Hose diameter Outside/Inside mm	Ordering No.
10/8	9721 4002 88
12/10	9721 4000 91
15/12	9721 4002 85

The spring guard should be used with the clamp nut above.

## MANIFOLDS

3/8 inlet on each side, 1/4 outlets for couplings



Thread Inlet in	Thread Outlet in	Number of outlets	Ordering No.
3/8 BSP	1/4 BSP	4	9090 0201 00
3/8 BSP	1/4 BSP	5	9090 0201 01
3/8 BSP	1/4 BSP	6	9090 0201 02

## MANIFOLDS

3/8 inlet on each side, 1/4 outlet on both sides for couplings



Thread Inlet in	Thread Outlet in	Number of outlets	Ordering No.
3/8 BSP	1/4 BSP	4	9090 0201 10
3/8 BSP	1/4 BSP	6	9090 0201 11
3/8 BSP	1/4 BSP	8	9090 0201 12
3/8 BSP	1/4 BSP	10	9090 0201 13



## Y-CONNECTIONS

2 female outlets and 1 male inlet

Model	Female thread in	Male thread in	Ordering No.
F/F/M08	1/4 BSP	1/4 BSP	9090 0201 86
F/F/M10	3/8 BSP	3/8 BSP	9090 0201 87
F/F/M15	1/2 BSP	1/2 BSP	9090 0201 85



## PIPE TEE

Model	Female threads in	Ordering No.
F08	1/4 BSP	9090 0201 51
F10	3/8 BSP	9090 0201 53
F15	1/2 BSP	9090 0201 50
F20	3/4 BSP	9090 0201 52
F25	1 BSP	9090 0201 54



## PIPE CROSS

Model	Female thread in	Ordering No.
F08	1/4 BSP	9090 0201 21
F10	3/8 BSP	9090 0201 22
F15	1/2 BSP	9090 0201 20



## BRANCH TEE

2 female outlets and 1 male inlet

Model	Female thread in	Male thread in	Ordering No.
2xF08 1xM08	1/4 BSP	1/4 BSP	9090 0201 61
2xF10 1xM10	3/8 BSP	3/8 BSP	9090 0201 63
2xF15 1xM15	1/2 BSP	1/2 BSP	9090 0201 60
2xF20 1xM20	3/4 BSP	3/4 BSP	9090 0201 62
2xF25 1xM25	1 BSP	1 BSP	9090 0201 64



## CROSS

3 female threads and 1 male thread

Model	Female thread in	Male thread in	Ordering No.
3xF08 1xM08	1/4 BSP	1/4 BSP	9090 0201 31
3xF10 1xM10	3/8 BSP	3/8 BSP	9090 0201 32
3xF15 1xM15	1/2 BSP	1/2 BSP	9090 0201 30



## RUNTEE

2 female outlets and 1 male inlet

Model	Female thread in	Male thread in	Ordering No.
F08/M08/F08	1/4 BSP	1/4 BSP	9090 0201 71
F10/M10/F10	3/8 BSP	3/8 BSP	9090 0201 72
F15/M15/F15	1/2 BSP	1/2 BSP	9090 0201 70



## PIPE ELBOW

Model	Female thread in	Ordering No
F08	1/4 BSP	9090 0201 40
F10	3/8 BSP	9090 0201 43
F15	1/2 BSP	9090 0201 41
F20	3/4 BSP	9090 0201 42
F25	1 BSP	9090 0201 44



## HEX HEAD PLUG

Model	Male thread in	Ordering No.
M08	1/4 BSP	9090 0201 81
M10	3/8 BSP	9090 0201 84
M15	1/2 BSP	9090 0201 80
M20	3/4 BSP	9090 0201 83
M25	1 BSP	9090 0201 82

## Pressure drop diagram for straight hoses

This diagram helps you to choose the right hose according to the air consumption of the tool and the length of the hose. The purpose of the diagram is to ensure that the pressure drop in the hoses does not exceed 0.2 bar.

### HOW TO READ THE DIAGRAM:

Look up the tools required air consumption at 6 bar.

Use this value in the diagram .

What length of hose do you need?

Look at the diagram to see which hose size you need.

Decide which type of hose you need, Atlas Copco Tools has seven different hoses covering all types of needs for pneumatic hand tools.

### EXAMPLE

The tool has an air consumption of 10 l/s and the application requires a hose length of 7 m. These two values have a cross point slightly under the 10 mm size hose (7 m of 10 mm hose gives a value of approximately 11 l/s).

Therefore a 10 mm hose will be suitable.

### PRESSURE DROP DIAGRAM FOR HOSES

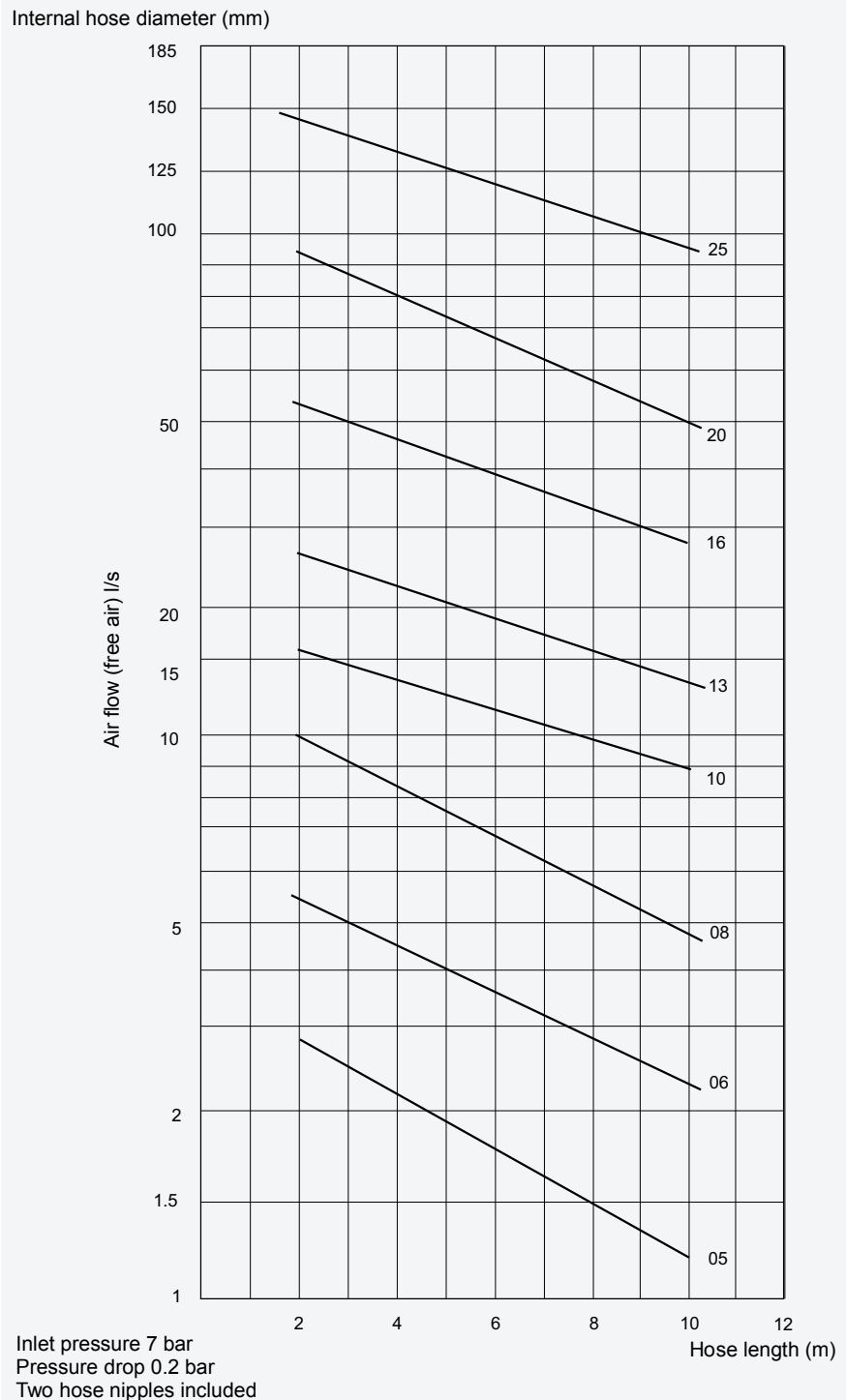

## CABLAIR HOSES

### SUPER-LIGHT FLEXIBLE PVC-HOSE

Cablair is made of high-strength, high performance PVC compound. The Cablair hose weighs 30-50% less and is much softer and more flexible than conventional PVC hoses. This ensures complete freedom of movement for operators of pneumatic hand tools.

- Low weight.
- Extremely soft and flexible.
- Silicone free.
- Ergonomic.
- Working temperature -15°C to +60°C.



Model	Hose inside dia		Hose outside dia mm	Max working pressure <sup>a</sup> bar	Max rec. air flow <sup>b</sup> l/s	Weight per 30 m coil kg	Ordering No.
	mm	in					
CABLAIR 06	6	1/4	8.5	14	4	1.2	9093 0035 11
CABLAIR 08	8	1/3	11	14	7.5	1.7	9093 0035 41
CABLAIR 10	10	2/5	13	12	13	2.1	9093 0035 71
CABLAIR 13	12.5	1/2	16	11	21	3.0	9093 0036 01
CABLAIR 16	16	5/8	21	8	43	5.4	9093 0036 31
CABLAIR 20	19	3/4	24	8	75	5.8	9093 0036 61
CABLAIR 25	25	1	31.5	7	125	10.4	9093 0036 91

<sup>a</sup> With a safety factor of 3 at 20°C (at the max temp of +60°C the working pressure should be reduced by 50%).

<sup>b</sup> The pressure drop will be 0.2 bar on a hose length of 5 m.

## CABLAIR ESD

### EXTRA FLEXIBLE ANTISTATIC AIR HOSE

Cablair ESD is designed specifically for use within the computer manufacturing industry. The hose possesses properties which enable ESDS (electrostatic sensitive devices) to be handled in a protected area with a low risk level, as a result of electrostatic discharge. In addition to a known demand in the computer industry, it is expected that potential exists in the electronics, radio and communication fields. The connection device must be earthed/grounded.

- Extra flexible.
- Antistatic.
- Silicone free.
- Testing in accordance with BS2050:1978 (1998) 4.12.
- Working temperature -15°C to +60°C.



Model	Hose inside dia		Hose outside dia		Max working pressure <sup>a</sup> bar	Max rec. air flow l/s	Weight per 30 m coil kg	Ordering No.
	mm	in	mm	in				
CABLAIR ESD 06	6	1/4	11	7/16	10	4	2.34	8202 0501 06
CABLAIR ESD 08	8	5/16	12	1/2	9	7.5	2.56	8202 0501 08
CABLAIR ESD 10	10	3/8	14	9/16	8	13	2.71	8202 0501 10
CABLAIR ESD 13	13	1/2	18	23/32	7	21	4.41	8202 0501 13

<sup>a</sup> With a safety factor of 3 at 20°C (at the max temp of +60°C the working pressure should be reduced by 50%).

## PVC HOSES

### STRONG PVC HOSE FOR HEAVY-DUTY APPLICATIONS

PVC hose has high resistance to abrasion, which makes it the ideal hose for tough working environments such as workshops, factories, garages, etc. It is mainly recommended for indoor use.

- Long service life.
- Pliable.
- Transparent.
- Working temperature -15°C to +60°C.



Model	Hose inside dia		Hose outside dia mm	Max working pressure <sup>a</sup> bar	Max rec. air flow <sup>b</sup> l/s	Weight per 30 m coil kg	Ordering No.
	mm	in					
PVC 03	3.2	1/8	7	20	0.7	1.4	9093 0037 21
PVC 05	5	3/16	9	10	2.1	1.9	9093 0037 51
PVC 06	6.3	1/4	11	10	4	2.5	9093 0037 81
PVC 08	8	5/16	12	10	7.5	2.9	9093 0038 11
PVC 10	10	3/8	14	14	13	3.7	9093 0038 41
PVC 13	12.5	1/2	18	13	21	5.9	9093 0038 71
PVC 16	16	5/8	22	12	43	7.2	9093 0039 01
PVC 20	19	3/4	25	10	75	8.3	9093 0039 31
PVC 25	25	1	32	10	125	12.5	9093 0039 61

<sup>a</sup> With a safety factor of 3 at 20°C (at the max temp of +60°C the working pressure should be reduced by 50%).

<sup>b</sup> The pressure drop will be 0.2 bar on a hose length of 5 m.

## POLUR

### HIGH RESISTANT POLYURETHANE HOSE

Polur hose is the most environmentally friendly solution. It has high resistance to abrasion and it is oil resistant. Polur hose has a much longer lifetime than PVC hoses. Polur is ideal in tough working conditions such as workshops, factories, garages, shipyards and construction sites due to its flexibility, even at minus degrees. Polur is recommended for indoor and outdoor use.

- Oil resistant.
- Flexible.
- Long service life.
- Working temperature -30°C to +60°C.



Model	Hose inside dia		Hose outside dia mm	Max working pressure <sup>a</sup> bar	Max rec. air flow <sup>b</sup> l/s	Weight per 25 m coil kg	Ordering No.
	mm	in					
POLUR 08	8	5/16	12	20	7.5	2.2	8202 0601 08
POLUR 10	10	3/8	14	16	13	2.5	8202 0602 10
POLUR 13	13	1/2	18	13	21	4.0	8202 0603 13

<sup>a</sup> With a safety factor of 3 at 20°C (at the max temp of +60°C the working pressure should be reduced by 50%).

<sup>b</sup> The pressure drop will be 0.2 bar on a hose length of 5 m, including 2 nipples and at an inlet pressure of 7 bar.



## TURBO SUPER-LIGHT FLEXIBLE RUBBER HOSE

Turbo hose has been developed for flexible use both indoor and outdoor. The hose weighs 30-40% less than conventional rubber hoses, making it ideal for foundries, shipyards, engineering workshops and construction sites. Turbo hose is oil resistant.

- Extremely low weight.
- Soft and flexible.
- Antistatic.
- Grinding and welding spatter resistant.
- Working temperature -30°C to +70°C.



Model	Hose inside dia		Hose outside dia mm	Max working pressure <sup>a</sup> bar	Max rec. air flow <sup>b</sup> l/s	Weight per		Ordering No.
	mm	in				20 m coil kg	30 m coil kg	
TURBO 13	13	1/2	19	20	21	3.9	–	9093 0057 91
TURBO 13	13	1/2	19	20	21	–	5.9	9093 0057 93
TURBO 16	16.8	2/3	22.8	20	43	4.8	–	9093 0057 31
TURBO 16	16.8	2/3	22.8	20	43	–	7.2	9093 0057 33
TURBO 20	21	5/6	27	20	75	5.4	–	9093 0057 61
TURBO 20	21	5/6	27	20	75	–	8.1	9093 0057 62

<sup>a</sup> With a safety factor of 3 at 20°C.

<sup>b</sup> The pressure drop will be 0.2 bar on a hose length of 5 m, including 2 nipples and at an inlet pressure of 7 bar.

## RUBBER DURABLE REINFORCED EXTRA THICK HEAVY DUTY RUBBER HOSE

The hose withstands rough handling and is suitable for the most demanding tasks in construction, mining, shipyards, foundries etc. The inner lining is black EPDM rubber, conductive to dissipate static electricity. Reinforcement with high tensile strength made of synthetic textile yarns.

- Durable.
- Antistatic.
- Grinding and welding spatter resistant.
- Working temperature -25°C to +70°C.



Model	Hose inside dia		Hose outside dia mm	Max working pressure <sup>a</sup> bar	Max rec. air flow <sup>b</sup> l/s	Length m	Weight kg	Ordering No.
	mm	in						
RUBBER	6.3	1/4	12	16	4	30	3.5	9030 2036 00
RUBBER	10	3/8	17	16	13	30	6.9	9030 2037 00
RUBBER	12.5	1/2	22	16	21	30	12.3	9030 2038 00
RUBBER	16	5/8	25	16	43	30	13.9	9030 2039 00
RUBBER	20	3/4	30	16	75	30	19.3	9030 2040 00
RUBBER	20	3/4	30	16	75	20	12.9	9030 2040 03
RUBBER	25	1	36	16	125	30	24.0	9030 2041 00
RUBBER	25	1	36	16	125	20	16.0	9030 2041 03

<sup>a</sup> With a safety factor of 5 at 20°C.

<sup>b</sup> The pressure drop will be 0.2 bar on a hose length of 5 m, including 2 nipples and at an inlet pressure of 7 bar.

## RUBAIR

### DURABLE REINFORCED HEAVY DUTY RUBBER HOSE

Rubair hose is double reinforced to fulfil all general heavy duty demands and is recommended for indoor and outdoor use. Rubair hose is oil resistant.

- Durable.
- Antistatic.
- Grinding and welding spatter resistant.
- Working temperature -20°C to +80°C.



Model	Hose inside dia		Hose outside dia mm	Max working pressure <sup>a</sup> bar	Max rec. air flow <sup>b</sup> l/s	Weight per 20 m coil kg	Ordering No.
	mm	in					
RUBAIR 10	10	3/8	16.0	16	13	3.6	8202 0402 10
RUBAIR 13	12.5	1/2	19.1	16	21	4.7	8202 0403 13
RUBAIR 16	16	5/8	23.0	16	43	6.1	8202 0404 16
RUBAIR 20	20	3/4	26.6	16	75	7.8	8202 0405 20

<sup>a</sup> With a safety factor of 5 at 20°C.

<sup>b</sup> The pressure drop will be 0.2 bar on a hose length of 5 m, including 2 nipples and at an inlet pressure of 7 bar.

## SPI

### ELASTIC HOSE FOR VERTICAL AND HORIZONTAL APPLICATIONS

SPI elastic spiral hose is ideal for air tools used at varying distances from a fixed air outlet. It is easily stretched and retracts immediately when released. When used with hand tools, its self-storage principle ensures that the hose is kept off the floor and out of the way of the operator. The SPI 1 and SPI 2 have ball bearing swivels fitted on the long hose side to allow 360° rotation. All spiral hoses, except the SPI4, are fitted with plastic spring guard. SPI is the ideal hose in combination with a balancer.

- Self-retractable.
- Light and flexible.
- Strong and durable.
- Tubing material: Polyurethane (100% PUR).
- Hardness: Shore A 98 +2.
- Colour: Blue.
- Working pressure: 8 bar at 23°C.
- Burst pressure: 25 bar at 23°C.
- Temperature range: -40°C to +70°C.



Model	Hose inside dia mm	Hose outside dia mm	Max. rec. air flow <sup>a</sup> l/s	Working range m	Length			Max spiral dia (D) mm	Male threads in BSP	Ordering No.
					(A) mm	(B) mm	(C) mm			
SPI 1SPSW-S	6.5	10	7	2	500	165	150	55	1/4	8202 0508 71
SPI 1SPSW-M	6.5	10	5	4	500	330	150	55	1/4	8202 0508 73
SPI 2SPSW-S	8	12	13	2	500	130	150	70	3/8	8202 0508 75
SPI 2SPSW-M	8	12	10	4	500	270	150	70	3/8	8202 0508 77
SPI 2SPSW-L	8	12	9	6	500	435	150	70	3/8	8202 0508 79
SPI 2SPSW-XL	8	12	6	8	500	600	150	70	3/8	8202 0508 81
SPI 3SP-S	11	16	25	2	500	135	150	98	3/8	8202 0508 82
SPI 3SP-M	11	16	22	4	500	260	150	98	3/8	8202 0508 84
SPI 3SP-L	11	16	17	6	500	390	150	98	3/8	8202 0508 86
SPI 3SP-XL	11	16	13	8	500	550	150	98	3/8	8202 0508 88
SPI 4SP-XXL	13	19	21	10	500	850	500	115	3/8	8202 0508 90

<sup>a</sup> At inlet pressure 6 bar and pressure drop 0.5 bar.

## Dimensions

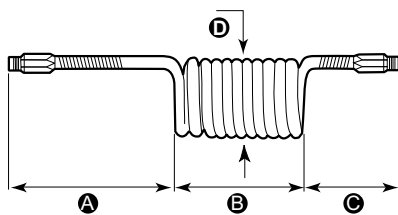

# Productivity Kits

Productivity kits boost productivity, extend tool lifetime and ensure minimum pressure drop.

Each productivity kit includes ball valve, air preparation unit, and the couplings, hose and nipples needed for correct and safe installation of the tool.

Just choose the correct productivity kit based on the air flow requirement of the tool and whether the tool needs lubrication or not. You'll be surprised how much the productivity kit improves the performance of the tool.

- Improves the performance of the tool.
- Fast and easy installation.
- Extends tool lifetime.



## PRODUCTIVITY KITS FOR SCREWDRIVERS, DRILLS AND GRINDERS

Model	Max air flow	Hose, 5 m	Coupling	Lubrication	Ordering No.
<b>For small screwdrivers and small drills with 1/8" BSP air inlet</b>					
MIDI Optimizer F/RD EQ08-C06-1/8	6 l/s	Cablair 6 mm	ErgoQIC 08	Yes	8202 0850 10
MIDI Optimizer F/R EQ08-C06-1/8	6 l/s	Cablair 6 mm	ErgoQIC 08	No	8202 0850 19
<b>For screwdrivers and drills with 1/4" BSP air inlet</b>					
MIDI Optimizer F/RD EQ08-C08	9 l/s	Cablair 8 mm	ErgoQIC 08	Yes	8202 0850 00
MIDI Optimizer F/R EQ08-C08	9 l/s	Cablair 8 mm	ErgoQIC 08	No	8202 0850 01
<b>For 1/2" drills and small nutrunners with 3/8" BSP air inlet</b>					
MIDI Optimizer F/RD EQ08-C10	16 l/s	Cablair 10 mm	ErgoQIC 08	Yes	8202 0850 07
<b>For 1/2" small nutrunners with 1/4" BSP air inlet</b>					
MIDI Optimizer F/RD EQ08-C10	16 l/s	Cablair 10 mm	ErgoQIC 08	Yes	8202 0850 03
MIDI Optimizer F/RD EQ10-R10	16 l/s	Rubair 10 mm	ErgoQIC 10	Yes	8202 0850 16
<b>For percussive tools and grinders with 3/8" BSP air inlet incl. whiphose</b>					
MIDI Optimizer F/RD EQ10-R13-W	23 l/s	Rubair 13 mm	ErgoQIC 10	Yes	8202 0850 14
<b>For percussive tools and grinders, incl. whiphose, no tool nipple included</b>					
MIDI Optimizer F/RD EQ10-R13-W	23 l/s	Rubair 13 mm	ErgoQIC 10	Yes	8202 0850 15
<b>For drills and nutrunners with 3/8" BSP air inlet</b>					
MIDI Optimizer F/RD EQ10-C13	23 l/s	Cablair 13 mm	ErgoQIC 10	Yes	8202 0850 02
<b>For drills and nutrunners with 1/4" BSP air inlet</b>					
MIDI Optimizer F/RD EQ10-C13-1/4	23 l/s	Cablair 13 mm	ErgoQIC 10	Yes	8202 0850 11
<b>For grinders and nutrunners with 3/8" BSP air inlet</b>					
MIDI Optimizer F/RD EQ10-T13	35 l/s	Turbo 13 mm	ErgoQIC 10	Yes	8202 0850 17
MIDI Optimizer F/RD EQ10-T16 (For LSV39)	35 l/s	Turbo 16 mm	ErgoQIC 10	Yes	8202 0850 42
<b>For grinders and nutrunners with 1/2" BSP air inlet</b>					
MIDI Optimizer F/R EQ10-T13	35 l/s	Turbo 13 mm	ErgoQIC 10	No	8202 0850 04
MIDI Optimizer F/RD EQ10-T13	35 l/s	Turbo 13 mm	ErgoQIC 10	Yes	8202 0850 13
<b>For grinders with 1/2" BSP air inlet</b>					
MIDI Optimizer F/RD EQ10-T16	40 l/s	Turbo 16 mm	ErgoQIC 10	Yes	8202 0850 12
<b>For large Turbo grinders with 1/2" BSP air inlet</b>					
MAXI F/R C-T16	60 l/s	Turbo 16 mm	Claw	No	8202 0850 05
<b>For large Turbo grinders with 1/2" BSP air inlet</b>					
MAXI F/RD C-T20	65 l/s	Turbo 20 mm	Claw	Yes	8202 0850 20

## PRODUCTIVITY KITS FOR IMPACT WRENCHES AND PULSE TOOLS

Model	Max air flow	Hose, 5 m	Coupling	Lubrication	Ordering No.
<b>For small impacts and pulse tools with 1/4" BSP air inlet</b>					
MIDI Optimizer F/RD EP EQ08-C08	9 l/s	Cablair 8 mm	ErgoQIC 08	Yes	8202 0850 35
<b>For 1/2" impact wrenches and pulse tools with 3/8" BSP air inlet</b>					
MIDI Optimizer F/RD EQ08-C10	16 l/s	Cablair 10 mm	ErgoQIC 08	Yes	8202 0850 36
<b>For 1/2" impact wrenches and pulse tools with 1/4" BSP air inlet</b>					
MIDI Optimizer F/RD EQ08-C10	16 l/s	Cablair 10 mm	ErgoQIC 08	Yes	8202 0850 37
MIDI Optimizer F/RD EQ10-R10	16 l/s	Rubair 10 mm	ErgoQIC 10	Yes	8202 0850 38
<b>For impact wrenches and pulse tools with 3/8" BSP air inlet</b>					
MIDI Optimizer F/RD EQ10-C13	23 l/s	Cablair 13 mm	ErgoQIC 10	Yes	8202 0850 39
<b>For impact wrenches and pulse tools with 1/2" BSP air inlet</b>					
MIDI Optimizer F/RD EQ10-T13	35 l/s	Turbo 13 mm	ErgoQIC 10	Yes	8202 0850 41

## PRE-MOUNTED HOSE KITS

Atlas Copco hose kits provides an easy way to choose the right hose and coupling combination for pneumatic tools. Each kit is ready for immediate use without the need of assembly tools.

- Correct combination hose – coupling.
- Leak free hose connections.
- Immediate use.



## HOSE KITS

Hose	Hose inside dia mm	Length m	Nipple	Coupling	Air inlet thread nipple	Ordering No.
Cablair	6	5	ErgoNIP 08	ErgoQIC 08	1/8" BSP	8202 1182 01
Cablair	6	5	NIP 08	ErgoQIC 08US	-	8202 1182 16
Cablair	6	5	ErgoNIP 10	ErgoQIC 08	1/8" BSP	8202 1180 67
Cablair	8	5	ErgoNIP 08	ErgoQIC 08	1/4" BSP	8202 1182 02
Cablair	8	5	NIP 08	ErgoQIC 08US	-	8202 1182 21
Cablair	8	5	ErgoNIP 10	ErgoQIC 08	1/4" BSP	8202 1180 77
Cablair	10	5	ErgoNIP 08	ErgoQIC 08	1/4" BSP	8202 1182 03
Cablair	10	5	ErgoNIP 10	ErgoQIC 08	1/4" BSP	8202 1180 30
Cablair	12.5	5	ErgoNIP 10	ErgoQIC 10	3/8" BSP	8202 1180 79
Cablair	12.5	5	ErgoNIP 10	ErgoQIC 10	-	8202 1182 10
Cablair	12.5	5	NIP 10US	ErgoQIC 10US	-	8202 1182 18
Cablair	12.5	8.5	ErgoNIP 10	ErgoQIC 10	-	8202 1182 20
Cablair	12.5	10	ErgoNIP 10	ErgoQIC 10	-	8202 1182 15
PVC	10	5	ErgoNIP 10	ErgoQIC 10	1/4" BSP	8202 1180 18
PVC	10	5	ErgoNIP 10	ErgoQIC 08	3/8" BSP	8202 1180 31
Rubair	10	5	ErgoNIP 10	ErgoQIC 10	3/8" BSP	8202 1180 20
Rubair	10	5	ErgoNIP 10	ErgoQIC 10	1/4" BSP	8202 1180 43
Rubair	12.5	5	NIP 10US	ErgoQIC 10US	-	8202 1182 24
Rubair	20	5	CLAW	ErgoQIC 10	-	8202 1180 24
Turbo	12.5	5	ErgoNIP 10	ErgoQIC 10	3/8" BSP	8202 1182 07
Turbo	12.5	5	ErgoNIP 10	ErgoQIC 10	1/2" BSP	8202 1180 22
Turbo	12.5	5	NIP 10US	ErgoQIC 10US	-	8202 1182 19
Turbo	16.8	5	ErgoNIP 10	ErgoQIC 10	1/2" BSP	8202 1180 34
Turbo	16.8	5	CLAW	ErgoQIC 10	1/2" BSP	8202 1181 80
Turbo	16.8	5	NIP 15US	ErgoQIC 15US	-	8202 1182 22
Turbo	16.8	10	ErgoNIP 10	ErgoQIC 10	-	8202 1180 46
Turbo	21	20	CLAW	ErgoQIC 10	-	8202 1181 75
Turbo	16	5	ErgoNIP-10-M10	ErgoQIC 10	-	8202 1180 51



## WHIP HOSE KITS

Hose	Hose inside dia mm	Length m	Nipple	Male thread	Ordering No.
Cablair	10	0.7	ErgoNIP 10	1/4" BSPT	8202 1180 19
Cablair	10	1.5	ErgoNIP 10	1/4" BSPT	8202 1182 30
Cablair	10	1.5	ErgoNIP 10	3/8" BSPT	8202 1182 35
Cablair	10	0.7	ErgoNIP 08	1/4" BSPT	8202 1180 47
PVC	10	0.7	ErgoNIP 08	3/8" BSPT	8202 1180 50
Rubair	10	0.7	ErgoNIP 10	1/4" BSPT	8202 1180 42
Rubair	10	0.7	ErgoNIP 10	3/8" BSPT	8202 1180 44
Rubair	12.5	0.7	ErgoNIP 10	1/2" BSPT	8202 1180 23
Turbo	16.8	0.5	ErgoNIP 10	1/2" BSPT	8202 1180 28
Turbo	16.8	5	CLAW	1/2" BSPT	8202 1181 95

## HM LIGHT

The HM Light has a robust design with a high impact composite casing. The outlet slot is optimized to provide an ideal pull-out angle for the hose. The HM Light is recommended for small and medium screwdrivers, small and medium pulse tools, small drills, impact wrenches up to 1/2" size and riveting and chipping hammers.

- Snap-on, pivoting wall bracket.
- PVC/PUR hose.
- Hose end provided with pressed fitting and steel spiral hose protector (NPT and BSP).
- Hose easily replaced when needed.
- Drum with ball bearings on both sides.
- Working temperature: 0°C - +50°C.
- Inlet hose length: 1 m.



Model	Hose length m	Hose type	Hose inside dia		Connection inlet	Connection distribution hose BSP	Max working pressure bar	Economical	Max air flow	Weight kg	Ordering No.
			mm	in	hose inside dia (cut of hose) mm			air flow (at 0.2 bar pressure drop) l/s	capacity (at 0.5 bar pressure drop) l/s		
HM LIGHT 8-8	8	PVC/PUR	8	5/16	10	1/4	12	4	7	3	8202 1183 30
HM LIGHT 8-12	12	PVC/PUR	8	5/16	10	1/4	15	3	5	5	8202 1183 31
HM LIGHT 10-10	10	PVC/PUR	10	3/8	10	3/8	15	6	10	5	8202 1183 32

## Dimensions

### HM LIGHT 8-8 (8-12)

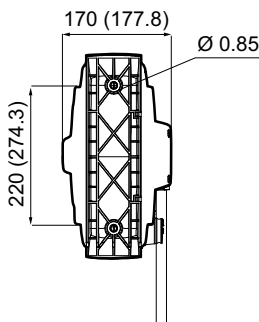
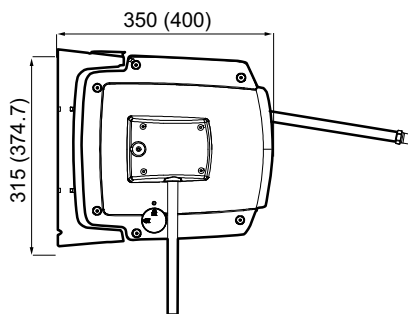

## FLOW CHART.

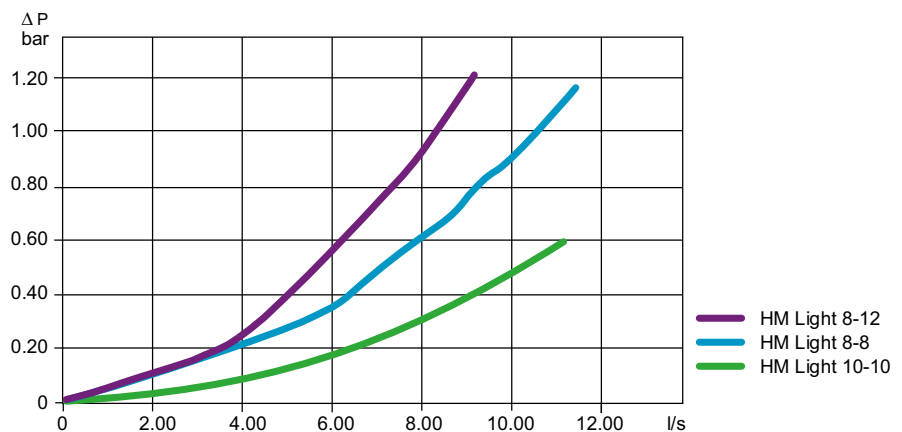

## HM OPEN

The HM Open has an open composite casing, steel frame and 10 mm or 13 mm hose. HM Open is a reliable, medium sized hose reel recommended for screwdrivers, impact wrenches, pulse tools, drills, chipping and riveting hammers and grinders up 1000 W.

- Spatter resistant rubber hose.
- Outlet roller position can be adjusted through 120 degrees for optimal pull-out angle.
- Hose end provided with steel spiral hose protector (NPT and BSP).
- Latch function is easily disengaged.
- Spring tension is easily adjusted.
- Floor, wall or ceiling mounting.
- Working temperature: -10°C - +60°C.
- Max working pressure: 15 bar.
- Inlet hose length: 1 m.



Model	Hose length m	Hose type	Hose inside dia		Connection inlet hose inside dia (cut of hose) mm	Connection distribution hose BSP	Economical air flow (at 0.2 bar pressure drop) l/s	Max air flow capacity (at 0.5 bar pressure drop) l/s	Weight	
			mm	in					kg	Ordering No.
HM OPEN 10-15	15	Rubber	10	3/8	12.5	3/8	5	9	11	8202 1183 33
HM OPEN 10-20	20	Rubber	10	3/8	12.5	3/8	5	7	14	8202 1183 34
HM OPEN 12-10	10	Rubber	12.5	1/2	12.5	1/2	13	22	12	8202 1183 35
HM OPEN 12-15	15	Rubber	12.5	1/2	12.5	1/2	11	17	13	8202 1183 36

Pivoting wall brackets needs to be ordered separately.

## Dimensions

HM Open 12-10 (12-15)

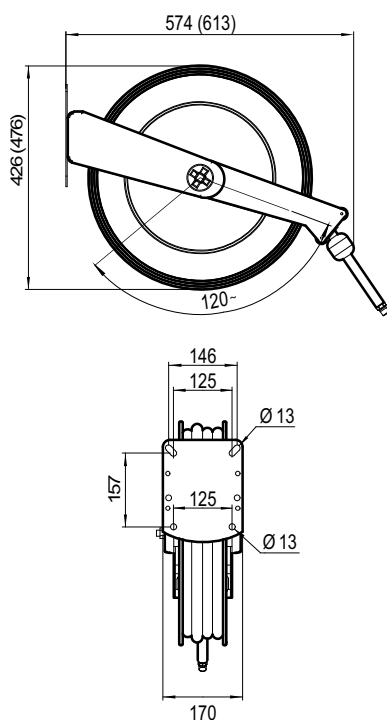

## FLOW CHART.

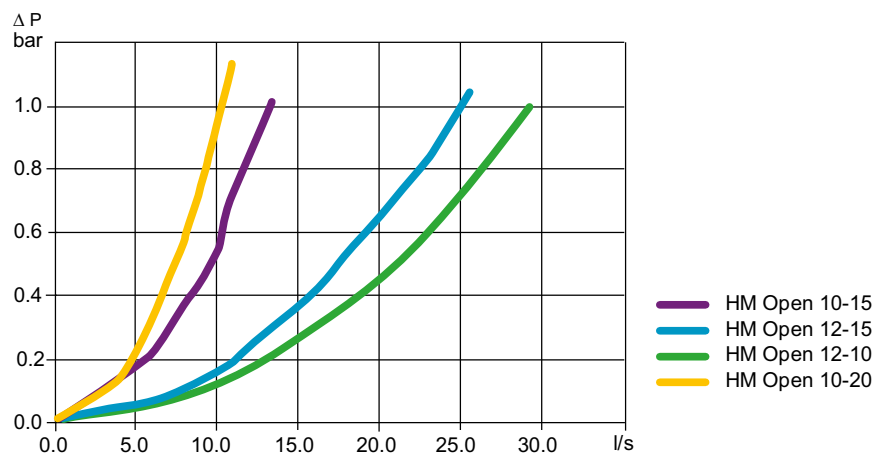

## Accessories

	Ordering No.
Pivoting wall bracket	4390 2080 10

## HM OPEN XL

Hose reels in the HM Open XL series have an open die cast aluminium casing and 3/8" or 1/2" hose. HM Open XL hose reels are recommended for screwdrivers, impact wrenches, pulse tools, drills, chipping and riveting hammers and high powered grinders.

- Spatter resistant rubber hose.
- Floor, wall or ceiling mounting.
- Revolving hinge for flexible use.
- Working temperature: -10°C - +60°C.
- Max working pressure: 15 bar.
- Inlet hose length: 1 m.



Model	Hose length m	Hose type	Hose inside dia		Connection inlet hose inside dia (cut of hose) mm	Connection distribution hose BSP	Economical air flow (at 0.2 bar pressure drop) l/s	Max air flow capacity (at 0.5 bar pressure drop) l/s	Weight	
			mm	in					kg	Ordering No.
HM OPEN XL 12-20	20	Rubber	12.5	1/2	12.5	1/2	8	14	27	8202 1183 37
HM OPEN XL 12-30	30	Rubber	12.5	1/2	12.5	1/2	8	12	28	8202 1183 38
HM OPEN XL 19-15	15	Rubber	19	3/4	19	3/4	27	44	28	8202 1183 39
HM OPEN XL 25-10	10	Rubber	25	1	25	1	60	95	30	8202 1183 40

Pivoting wall brackets needs to be ordered separately.

## Dimensions

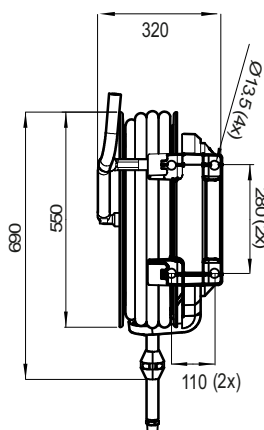
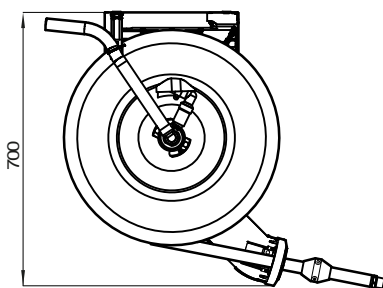

## FLOW CHART.

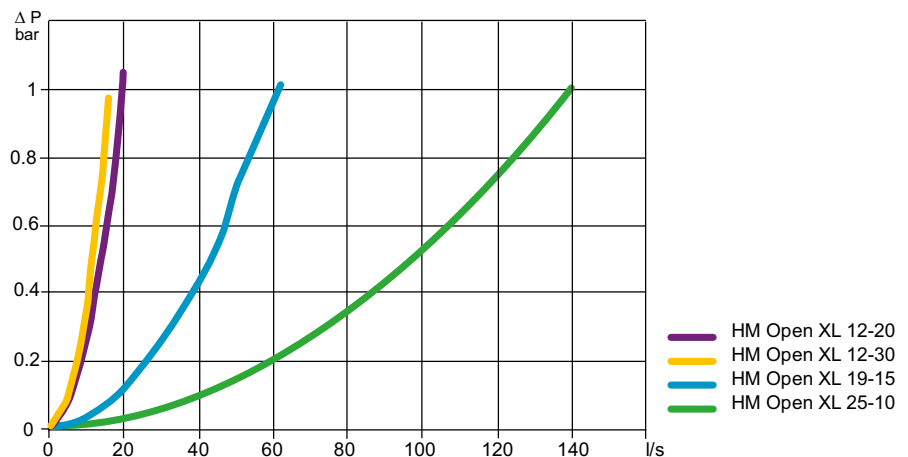

## Accessories

	Ordering No.
Pivoting wall bracket	4390 2080 11



## HM FLEX L

The HM FLEX L, with a steel casing and high quality rubber hose, handles both air and water. The HM FLEX L is recommended for all screwdrivers, pulse tools, impact wrenches, drills, chipping and riveting hammers and grinders up to 1000 W.

- NBR rubber hose.
- Movable brackets for floor, wall and ceiling mounting.
- High flow capacity.
- Working temperature: -30°C - +60°C.
- Max working pressure is 15 bar.
- Inlet hose length: 1 m.



## Dimensions

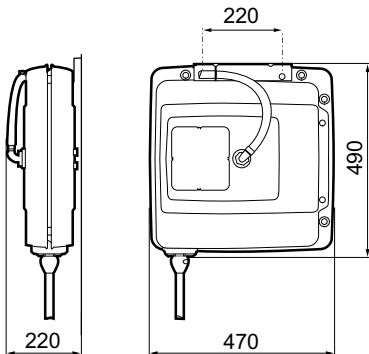

Model	Length m	Hose	Hose inside dia		Connection inlet BSP male	Connection distribution hose BSP male	Air flow l/s	Weight kg	Ordering No.
			mm	in					
HM FLEX L	10	Rubber	12.5	1/2	1/2	1/2	22	16	8202 1181 56

## RIL BALANCER

RIL balancers always keep the tool in place, handy and easily accessible. RIL balancers are available as retractors or weightless positioning balancers.

Safety chain included with all RIL balancers.

## RIL RETRACTORS

- Adjustable wire stop.
- High quality spring and construction.
- Load range 0 to 10 kg.

## HOSE REEL BALANCER – HRIL

Models in the HRIL range of hose reel balancers are specifically designed for use with small pneumatic hand tools.

The integrated air hose and support cable ensure the work area is kept tidy and the tool is easy to control.

- Ergonomics – The retraction force over hose travel remains almost constant which minimizes load on the operator and ensures smooth operation.
- An easily adjusted rubber stop is fitted on the hose which allows the tool to be set at the optimum position.
- The retraction force is easily ad.



Model	Capacity range		Max rec. air flow <sup>a</sup> l/s	Hose travel m	Weight		Max working pressure bar	Dimensions			Ordering No.
	kg	lb			kg	lb		A mm	B mm	C mm	
HRIL 1	0.2-0.5	0.4-1.1	3.5	1.2	1.2	2.6	10	92	132	173	8202 0600 03
HRIL 3	0.5-1.4	1.1-3.1	5.5	1.0	1.2	2.6	10	92	132	173	8202 0600 11
HRIL 4	0.7-2.0	1.5-4.4	6.5	1.0	1.4	3.1	10	92	132	173	8202 0600 29

<sup>a</sup> At inlet pressure of 6 bar pressure drop is 0.4 bar.

## Dimensions

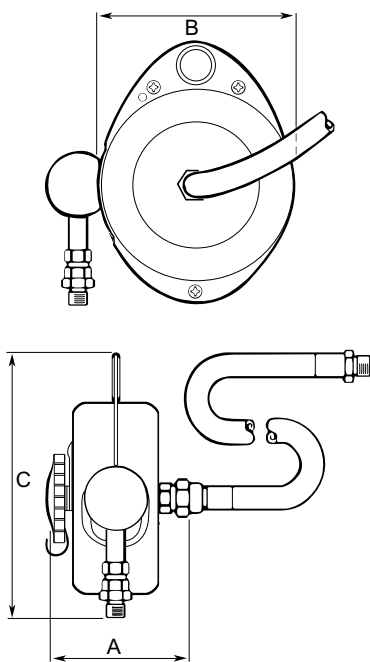

## Optional Accessories

Designation	Ordering No.
Safety chain	4391 4045 90

### BLOW GUN BG-SERIES

Atlas Copco blow guns BG-series are hard wearing, user friendly solution for all cleaning applications. The plastic body offer flexibility in handling for both left and right handed users, it insulate against cold and it reduce the risk of scratches to worksurfaces. The blow gun has excellent throtteling properties allowing easy regulation of the air flow. The blow guns have air inlet thread in brass that is fully covered by the plastic body. Two versions available with star tip to reduce risk of damages or injuries if the tube is pressed against workpiece or skin.

- High flow capacity.
- Suspension.
- Plastic body to avoid scratches.
- Air inlet thread in brass.
- Star tip availability for improved safety.
- Complies with OSHA STD1-13.1 and OSHA 1910.95.



Model	Version	Working pressure bar	Air flow l/s	Weight		Air inlet thread BSP	Ordering No.
				kg	lb		
BG 2603-HF	Long tube, high flow	6.3	7.5	0.13	0.29	1/4	8202 1006 04
BG 2604-SHF	Short tube	6.3	4.3	0.12	0.26	1/4	8202 1006 05
BG 2605-STSS	Short tube, star tip	6.3	6.6	0.12	0.26	1/4	8202 1006 06
BG 2606-STS	Long tube, star tip, silencer	6.3	6.3	0.14	0.31	1/4	8202 1006 07

## Test Equipment

### PRESSURE CONTROL UNIT

The unit consists of a high quality pressure gauge and the necessary couplings for checking the air pressure at the air inlet of the machine.

Ordering No. 4145 0699 81.

