



## TrailerVac SET-10T

***The TrailerVac SET-10T suction units meet the high demands from the industry due to its efficiency, reliability, ease of operation and maintenance giving excellent value for money.***

The TrailerVac SET-10T units are a series of mobile, electrical powered vacuums loaders that are fitted onto trailers chassis. Dry material and even liquids can be handled by the units. Together with a fixed pipe network they can operate as a perfect central vacuum unit for industrial installations.

- Rigid design for industrial use
- Roots-type high vacuum pump (50-80%)
- Filter system for dry and wet material
- Automatic filter cleaning without compressed air
- Electrical motor 30 to 55 kW
- Large dustbins with tailgate for easy discharge
- Very low noise level

### **WHY TrailerVac SET-10T**

Most heavy industry sites have raw material handling, production, packing etc. often located to several different buildings, with some distances between the premises. In these cases ordinary stationary central vacuum cleaning system is unable to serve everything. This is why the TrailerVac SET-10T is a suitable choice. The high suction capacity together with the large collecting hopper volume, all placed onto a trailer for towing by a tractor or similar makes the whole unit easy to transport as it is operational as soon a hose/pipe is connected together with an electrical power plug. Also the handling of the dust is easily carried out as there is a built-in tipping cylinder for the discharge.

The rigid trailer can carry high load together with high suction capacity using Roots pump makes the unit especially suited for heavy industrial environments.

### **OPERATION**

The vacuumed material is first separated in a specially designed fall chamber with a wear proof pre-separator inlet. In this section the heavier particles fall to the bottom of the container.

*The TrailerVac SET-10T suction units are equipped with built-in hydraulic tipping system and are towed/connected to i.e. a tractor*

From this section the air will be lead to the main filter section where any remaining fine dust will be separated. From the filter section the air passes a safety filter before entering the vacuum pump and a silencer before exhaust.

Due to the well insulated motor compartment housing the noise level of the unit is extremely low.

An unloading valve is placed between the main filter system and the vacuum pump. The vacuum will immediately be equalised when the valve is opened and at the same time the main filters will be cleaned. This will also prevent counter-rotation of the motor as well as less power consumption at starting. It will also be activated by safety control functions.

All functions are controlled at the dust-tight control panel and control lamps will indicate the units operational status.

### **APPLICATIONS**

For use in any industrial application where collection of dust is required i.e. to clean out; deep pits, trenches, bucket elevators, conveyor spills, overhead cranes and runways, dust collectors, processing machines etc.

The unit is specially suitable where bulky or sticky material shall be collected due to it's convenient discharging.

### **TYPICAL USERS**

Manufacturers of Cement, Lime, Gypsum, Tiles, Ceramics, Chemicals, Plastics, Fertilizers and Alumina.

Foundries, Steel mills, Quarries, Mines, Pulp- and Paper Industry, Incineration Plants, Thermo-electric Power Plants, Painting Contractors/Shipyards, Cleaning Contractors...

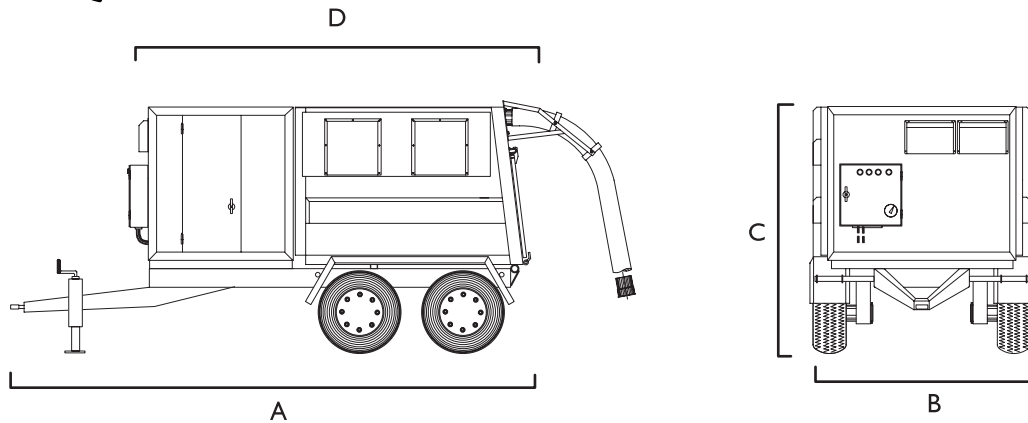

## TrailerVac SET-10T

### VACUUM PUMP

The vacuum producer is a Roots-type vacuum pump, powered by an electrical motor and V-belt transmission. Pump and motor is mounted on a common steel structure machine frame, which also is the exhaust silencer.

The vacuum pump is equipped with a spring loaded safety valve regulating the vacuum not to exceed its maximum operating range. Further there are a temperature switch and a safety filter for extra protection of the pump.

The drive motor is equipped with a motor protective switch. The drive part is built into an insulated steel enclosure with silencers to reduce noise level and fitted with service doors for access purposes.

### FILTER SYSTEM

Filter compartment contains a cassette filter with flat filter bags, made of specially treated polyester needle felt. Service of filters is easy from the clean gas side on the outside of the unit.

The filter system is equipped with a vacuum controlled ATM (air-repulse) filter cleaning system. When activated, large air inlets will ensure a fast backwards air direction through the filters, thus in an efficient way knocking off collected dust from the filter surface.

### DUST BIN

Type: Container, Tailgate-door with manual locking (Hydraulic controlling, watertight, option)

Volume: 3,5 m<sup>3</sup> air volume

### MISCELLANEOUS

Trailer: 10 tonnes capacity  
 Tipping Cylinder: Hydraulically 8 tonnes capacity  
 Filter class: L, M IEC EN 60335-2-69  
 Hose connect. Dia 152 mm or smaller  
 Material: Steel S 235 JG2  
 Painting: System C2, RAL 3003 red  
 Max towing speed: 30 km/h

### OPTIONS

- Aut. Jet Pulse Filter Cleaning
- DP-Gauge incl. Ball Valve
- DP-Switch Safety Filter
- Extra Noise Insulation for ATM Valve
- Hydraulic Operation/Locking Tail Gate
- Hydraulic Unit, for Tipping/ Tail Gate Operation
- Level Control; Paddle type or Vibrating type
- Line (Circuit) Breaker
- Pre Designed for Remote Control 24 V
- Radio Remote Control(CE,Carrier vave interr.)
- Star-Delta -Starter
- Temp Switch Motor
- Timer Auto Stop
- V-Belt Cover
- Vacuum Timer Stop
- Ventilator Cooling
- ATEX max ST1 outdoor Execution, according to CE
- HEPA-Filter

Item/Model		SET-10T.30	SET-10T.37	SET-10T.45	SET-10T.55
Dimensions, mm	A	5420	5420	5420	5420
	B	2100	2100	2100	2100
	C	2600	2600	2600	2600
	D	3700	3700	3700	3700
Weight, kg (approx)		3700	3850	4200	4250
Max Vacuum, mbar		500	500	500	500
Air Volume m <sup>3</sup> /h (unloaded)		1855	2245	2617	3360
Electrical Motor, kW		30	37	45	55
Voltage Frequency, V/Hz		400/50	400/50	400/50	400/50
Main Filter surface, m <sup>2</sup>		15	15	15	18
Safety Filter Surface, m <sup>2</sup>		20	20	20	20
Noise Level dB(A) (at 1 m/5 m distance)		65	67	70	71
Layout		SD-10055	SD-10055	SD-10055	SD-10055

We reserve the right to alter any specifications without prior notice

#### Manufacturer:

**DISAB-TELLA AB**  
 Cedersdalsvägen 1  
 SE-186 40 Vallentuna  
 Sweden

Tel: +46 (0) 8 514 505 70  
 Fax: +46 (0) 8 511 754 66  
 E-mail: industrial@disab.com  
 www.disab.com

#### Distributor: