



Quantima<sup>®</sup>

Unique Innovation • Outstanding Efficiency

# Quantima<sup>®</sup>

high speed | oil-free | variable speed | centrifugal compressors

CompAir Quantima - delivering a major breakthrough in oil-free compressor technology

**Outstanding efficiency** •

**Premium reliability** •

**Lower environmental impact** •

Q-drive™



“Simplicity. The ultimate sophistication”

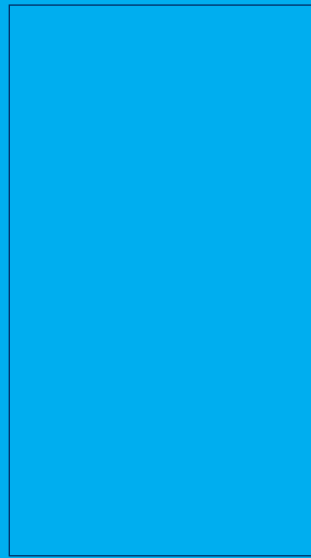

Quantima's patented Q-drive compression and motor assembly has just one moving part and operates with the rotor spinning in a magnetic field at up to 60,000 rpm.

Q-drive is special for what it doesn't have:

- **No gearbox**
- **No oil**
- **No contact**
- **No wear**



CompAir Quantima *the future is here*

Quantima's innovative compressed air technology is at the heart of energy savings and efficiencies for our customers

**Quantima delivers a range of benefits to customers globally, the most tangible of which is energy savings, directly and significantly benefiting both the environment and the customer's bottom line. Quantima is a smaller, quieter compressor with zero risk of oil contamination and the added peace of mind delivered with extremely reliable operation and 24/7 remote monitoring and predictive maintenance.**

**CompAir's Quantima delivers a major breakthrough in oil-free compressor technology.**

**Quantima**<sup>®</sup>

Quantima is installed and actively providing major efficiencies and cost savings in the following industries:

- Technology
- Food & Beverage
- Pharmaceuticals
- Healthcare
- Automotive
- Pulp & Paper
- Chemicals
- Packaging
- Energy
- Glass

**CompAir Quantima** - satisfaction is knowing that customer's expectations have been met and exceeded.



Just six months after installing new Quantima compressors from CompAir, Jaguar Land Rover's (Jaguar) Castle Bromwich plant is on target to achieve annual electricity savings in the region of 3 million kWh, with a payback on return on investment within two years.

**Jaguar Land Rover, United Kingdom**

Following installation, an independent engineering consultancy tested the performance of the compressor station. The results were even better than CompAir's original forecasts, with energy efficiency up to 5% higher than expected.

**Daimler Mercedes Benz, Germany**

Unlike other conventional compressors that we have considered, Quantima's Q-Drive assembly has only one moving part, the rotor shaft, which has no contact and no wear – helping us to lower our operating costs and reduce our environmental footprint.

**Ahlstrom, Finland**

Prior to the Quantima installation, our compressed air system was using 9.1 kW to generate each cubic metre of air per minute. Now, with Quantima, this specific power consumption has reduced significantly to just 6.12 kW/Nm<sup>3</sup>/min. In simple terms, we are now producing compressed air at best practice levels and with much better efficiency – to the effect, it is now taking 35% less power for us to generate a higher air output.

**Murray Goulburn, Australia**



“To design something complex is easy.  
To design something this simple is difficult”

**Magnetic Bearing**

The motor and direct drive compression assembly incorporates magnetic bearings to provide stable control both axially and radially of the rotor shaft. The shaft is supported in a magnetic field which means that there is no contact and no wear ensuring reliable operation and long life.

**Q-drive High Speed Motor**

The patented Q-drive motor incorporates an asynchronous induction design and operates at high speeds to avoid the need for a conventional gearbox. This eliminates the costly gearbox losses and means that the compressor does not require any oil at all.

**Inlet Filters**

High efficiency inlet air filtration for effective protection of the compression assembly. The filters provide one micron, high capacity particle filtration resulting in lowest pressure drops and longest service life.

**Stainless Steel Coolers**

Packaged shell and tube intercooler and aftercooler. Comprises water in tube stainless steel straight tube design as standard for long service life and simple maintenance.

**Q-master Controller**

Provides for the comprehensive control and protection of the compressor's operation. It incorporates a touch screen panel as well as intuitive navigation and menu structure for easy-to-use operation. It also includes sophisticated control methodology and surge calibration designed to minimise energy consumption.

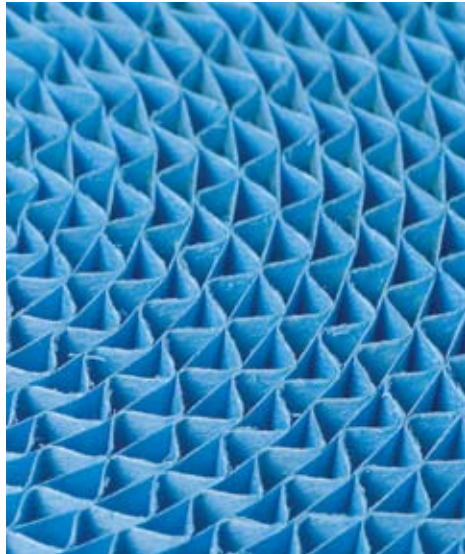
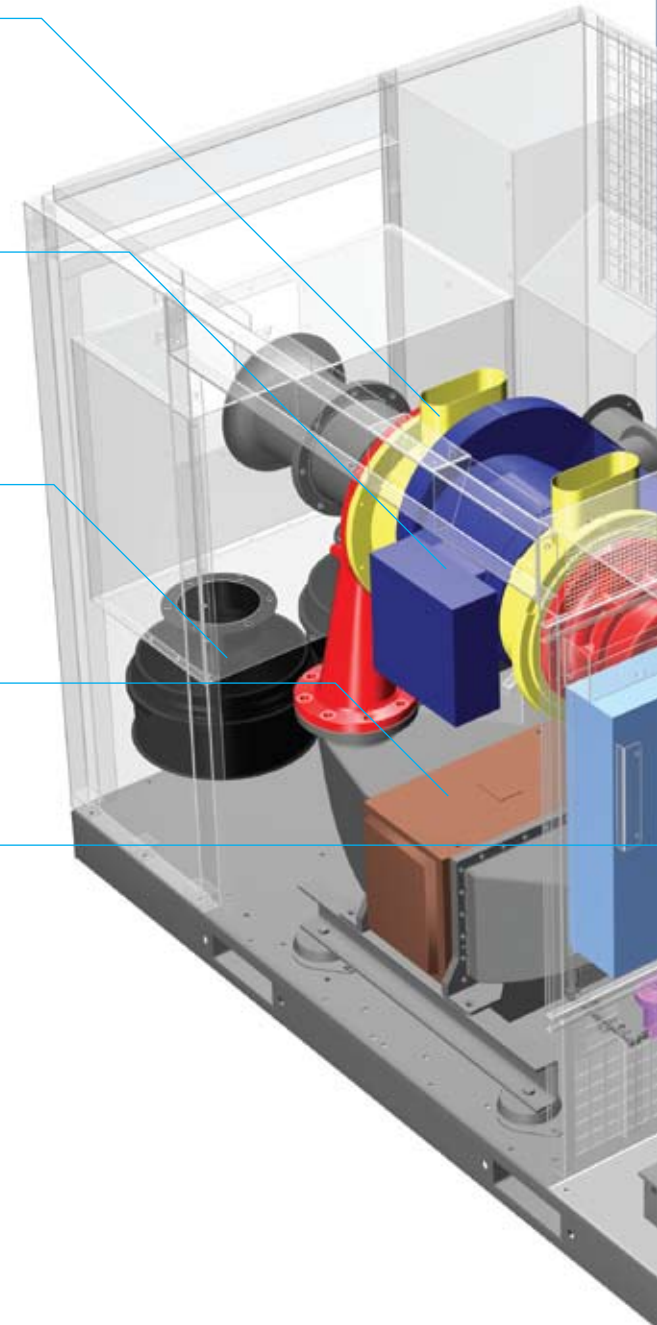

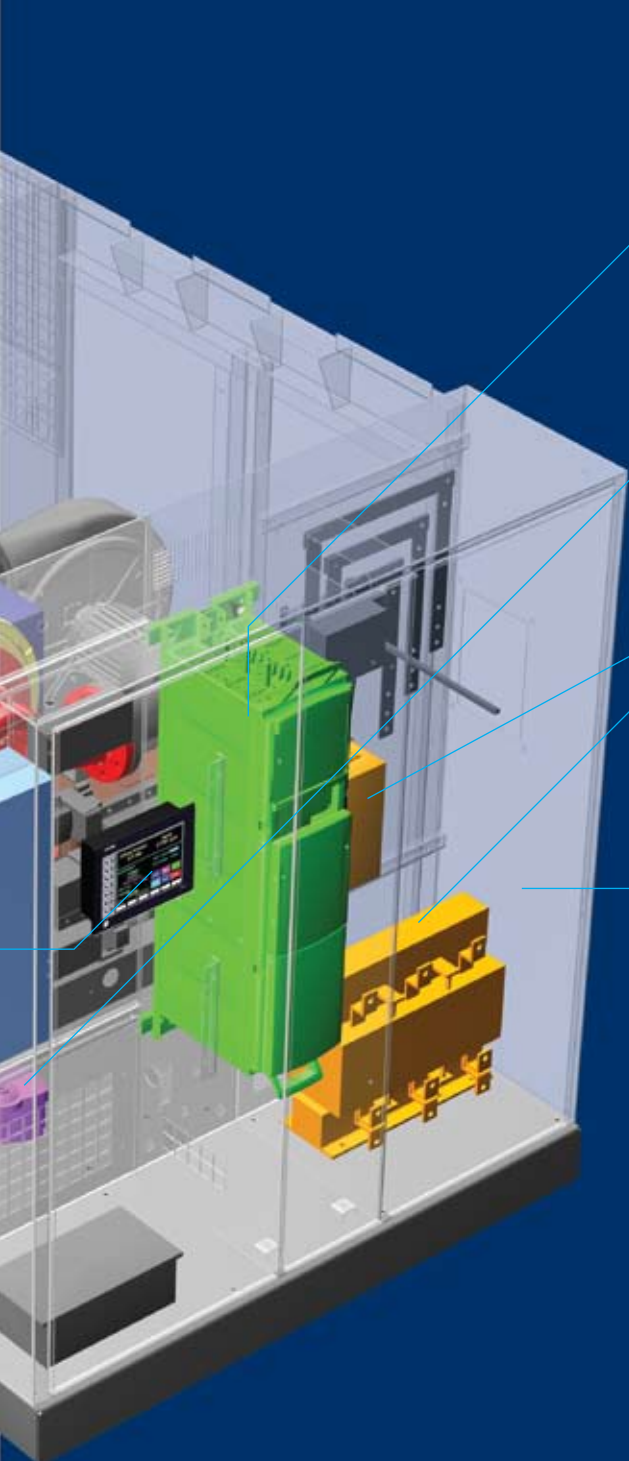

### **Variable Speed Drive**

The high frequency inverter variable speed drive acts as an electronic gearbox. Not only does it allow for the required high speeds for compression, it also provides variable speed operation to match compressor flow to plant demand and hence minimise power consumption.

### **Zero Loss Drains**

The Quantima package is fitted with zero loss drains which automatically drain condensate from the package based on level sensors. These are fitted on both the intercooler and aftercooler and condensate strainers are also fitted on the inlet of the drains. Manual drains are also included.

### **EMC Filter and Input Choke**

The Quantima package incorporates Input Choke on the incoming mains power to protect the compressor drive from abrupt changes to incoming power supply and also function as protection against harmonics back to the mains supply. An EMC filter is also fitted to attenuate any electro magnetic noise at higher frequencies that may cause harm to external equipment.

### **Acoustic Canopy**

The compressor is housed in a modular acoustic canopy with intelligent sound attenuation resulting in noise levels which are the lowest of any compressor in this class – just 69 dB(A).

### **Simple Installation**

The Quantima compressor is a fraction of the weight and a fraction of the size of equivalent compressors meaning it has a significantly smaller physical footprint. In addition, the compressor incorporates a soft start VSD drive to ensure there is no current peak on start up.

In Quantima, CompAir have developed a truly unique innovation providing world-class performance and efficiency, reducing your costs significantly



No gearbox and no contact, just a single moving part spinning in a magnetic field. Of course it's a world-class compressor, offering outstanding efficiencies



The greatest efficiency is that which can utilise technology to the best advantage



Quantima Air Compressors deliver significant benefits over traditional technology. Energy **savings of up to 25% and more** are easily achievable with Quantima.

A major leap forward in compression technology developed and patented by CompAir – it's easy to see how this innovative compressor is set to revolutionise energy savings and efficiencies.





- Outstanding efficiency due to no gearbox and no contact parts
- Energy savings of up to 25% and more are easily achievable
- **Lowest off-load power consumption – just 2.5% of full load power equal to 7kW for a 300kW compressor**

- Variable speed technology matches output to requirement minimising off-load running
- Sophisticated compressor controls to maximise flexibility and provide additional power savings

**Lower energy** across the entire flow range

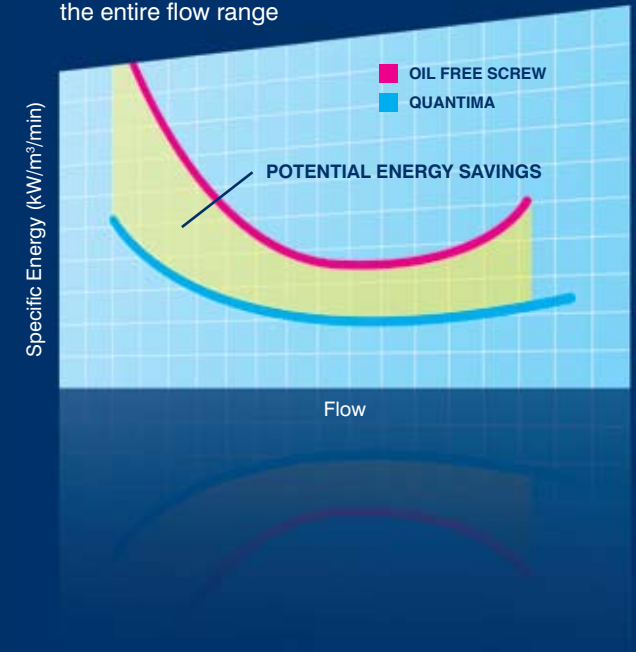

**No performance degradation** over life of compressor unlike standard screw technologies with wearing parts

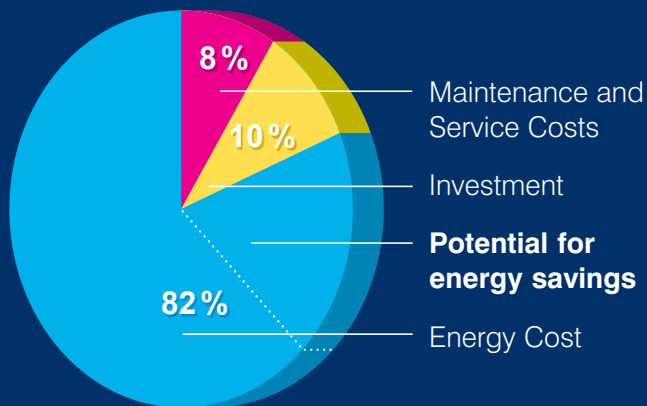
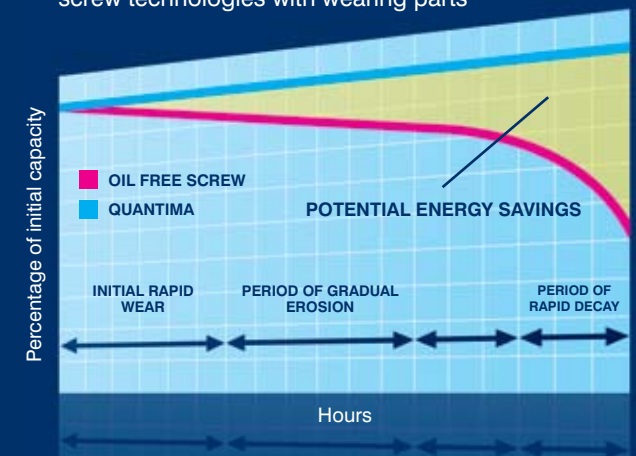

**Lower energy consumption – lower cost of ownership**

Energy costs account for approximately 80% of the outlay over the life of the compressor - making energy efficiency our number 1 priority.

**With energy savings of up to 25% and more, Quantima delivers.**

“We make the world we live in and shape our own environment”

Quantima saves on power, which means lower carbon loading. We use less physical resources to build and maintain Quantima and don't use a drop of oil anywhere in the compressor, so there is no oil or oil-laden parts to dispose of.

When it comes to delivering an environmentally friendly air compressor solution, CompAir's Quantima offers outstanding energy savings, waste savings and reduced CO<sub>2</sub> emissions.

Quantima offers a reduced environmental footprint, cutting tonnes of CO<sub>2</sub> during manufacture, use and disposal, increasing your 'green' credentials and market appeal



CompAir's commitment to providing the purest, highest quality compressed air, through the development of innovative products, delivers world-class solutions.

Dedicated to improving performance and efficiency for our customers, at the same time lowering the impact on our environment, CompAir are clearly focussed on developing unique innovation to benefit all markets.

- Lower carbon emissions through lower energy use
- Lowest physical resources in manufacture and maintenance
- Lowest physical foot print and 40-50% of the size and weight of an equivalent machine
- Lowest noise levels of just 69 dB(A)



### Potential CO<sub>2</sub> reduction of 1,920 tonnes in 10 years

% Reduction	Energy	Waste	CO <sub>2</sub>
In Manufacture	67% less	78% less	60% less
In Use	10% less	65% less	12% less
In Disposal	29% less	66% less	30% less

\* European Commission EuP EcoReport Version 3a  
Comparison to 300kW Oil free Screw Compressor

Over a ten-year period compared to traditional screw technologies, a 300kW Quantima unit can reduce the amount of CO<sub>2</sub> produced by 1,920 tonnes.

**That offsets the total emissions from 75 family cars or is equal to planting 16,000 trees\*.**

# Q-life service package delivers the risk-free peak performance, quality, efficiency and world-class reliability that you need, day after day

## Q-LIFE™

The simplicity provided by Quantima's innovative technology delivers minimum downtime and world-class reliability - not only saving money on maintenance but also providing peace of mind and zero risk.

Quantima's Q-life package is based on a predictive maintenance philosophy where we constantly monitor the performance of each unit to deliver premium reliability and performance. Comprehensive remote monitoring allows us to service components before they create an issue and if something

does go wrong, however unlikely, we'll know about it first and already be responding.

Unlike most other maintenance packages, Q-life covers all servicing under a single fixed cost ensuring that our customers receive an extremely cost effective solution.

“The best thing that technology can give us - is that it just works”

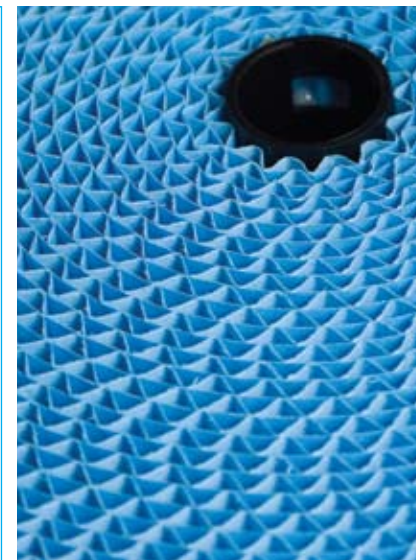

Q-master controller forms an integral part of the Q-life service package



no exceptions *no surprises*

### Quantima's fewer parts deliver world-class reliability and peace of mind

Component	Quantima	Standard Screw Technology
Gears	0	7
Bearings	4	19
Seals	2	17
Oil system	0	1

- Delivers outstanding performance and reliability
- Predictive maintenance via remote monitoring
- Peace of mind and zero risk
- Single fixed cost

CompAir Quantima – an advanced compression technology delivering superb efficiency and high quality, quiet oil-free compressed air



Medium Pressure Models	Cooling Method	Motor Rating (kW)	Working Pressure min / max (bar g)	FAD @ 7 bar g (m <sup>3</sup> /min)*	Dimensions L x W x H (mm)	Noise Level dB(A) **	Weight (kg)
Q-26	Water	150	5 / 8	26.7	2400 x 1600 x 1850	69	2400
Q-34	Water	190	5 / 8	33.8	2400 x 1600 x 1850	69	2400
Q-43	Water	240	5 / 8	44.4	2400 x 1600 x 1850	69	2600
Q-52	Water	300	5 / 8	52.7	2400 x 1600 x 1850	69	2600

Low Pressure Model	Cooling Method	Motor Rating (kW)	Working Pressure (bar g)	FAD (m <sup>3</sup> /min)*	Dimensions L x W x H (mm)	Noise Level dB(A) **	Weight (kg)
Q-70L	Water	300	3	70.9	2950 x 2000 x 1950	69	3800
	Water	300	4	70.0	2950 x 2000 x 1950	69	3800
	Water	300	5	65.4	2950 x 2000 x 1950	69	3800

\* Data measured and stated in accordance with ISO 1217, Ed. 4, Annex C & E at the following conditions:  
 Air Intake Pressure: 1 bar a / 14.5 psia,  
 Air Intake Temperature: 20°C / 68°F,  
 Humidity: 0% (dry)

\*\* Measured in free field conditions in accordance with the ISO 2151 test code, tolerance  $\pm$  3dB(A)

## DO YOU WANT TO KNOW EXACTLY HOW MUCH YOU COULD SAVE?

You know that energy is by far the biggest cost associated with your compressed air system. Quantima can deliver significant power savings in your compressed air generation, but so too can improvements in your compressed air distribution and use. Comprehensive measurement and analysis of your

compressed air systems can tell you exactly what compressed air is costing you, highlight areas for improvements and realistically quantify the potential for savings. Contact your local CompAir representative to get some assistance as assessing the potential for savings at your site.



## Like the compressor itself, the Quantima options are designed to be environmentally friendly and energy efficient

The 'Heat Recovery' option allows customers to recoup the vast majority of energy input to the compressor in the form of reusable hot water. This can provide a valuable source of energy for many industries with processes where hot water or steam are used, as well as in applications like space heating.

For customers requiring the high quality of compressed air that adsorption dryers can provide, the Quantima 'Heat of Compression Dryer' option uses the heat from the compression process to regenerate the adsorption beds, meaning that no additional heaters are required, hence saving further energy.

## Quantima options

- Energy Recovery Kit
- Weatherproof Kit
- Heater Kit
- Connectivity with Building Management Systems (BMS)
- Heat of Compression Dryer
- Closed-loop cooling water systems



Out of intense complexities,  
powerful simplicities emerge



[www.compair.com](http://www.compair.com)  
[www.quantima.com](http://www.quantima.com)